

Vacuum pump EVE-OG 40 AC3 F

Part no.: 10.03.02.00031

<https://www.schmalz.com/10.03.02.00031>



Homepage > Vacuum Technology for Automation > Vacuum Components > Vacuum Generators > Vacuum Pumps > Oil-Lubricated Vacuum Pumps EVE-OG > EVE-OG 40 AC3 F

Oil-lubricated pump for maximum vacuum levels, requires little maintenance



Current type: 3-phase AC
 Noise level: 64 dB
 with: Filter
 Voltage (50Hz): 200-240V or 345-420V
 Suction rate (50Hz): 40 m³/h
 Rated power (50Hz): 1.1 kW
 Weight: 38 kg

Design Data

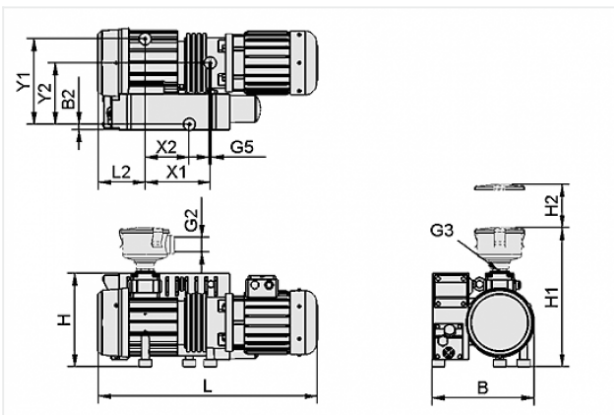

Attribute	Value
B	284 mm
B2	15 mm
G2	G1-1/4"-F
G3	G1-1/4"-F
G5	M8-F
H	260 mm
H1	390 mm
H2	75 mm
L	625 mm
L2	130 mm
X1	179 mm
X2	123 mm
Y1	238 mm

Contact to Schmalz

J. Schmalz GmbH | Johannes-Schmalz-Straße, 72293 Glatten, Deutschland | +49 7443 2403-102 | customercenter@schmalz.de

Attribute	Value
Y2	171 mm

Technical Data

Attribute	Value
Vacuum (max)	-980 mbar
Vacuum (max)	-28.939 inHg
Suction rate (50 Hz)	40 m ³ /h
Voltage (50 Hz)	200-240V or 345-420V
Rated power (50 Hz)	1.1 kW
Noise level (50 Hz)	64 dB
Weight	38 kg
Protection	IP 54
Current type	AC3

Spare Parts



FILT-EINS 3 98x70 PAP STF-1-1/4-IGN

Part no. 10.07.01.00018

Filter insert (round)

Filter pore size: 3 µm

External diameter D: 98 mm

Length L: 70 mm

Filter material: Paper

for: Filters STF

Size: 1-1/4-IGN



VST EVE-OG-25-40

Part no. 10.03.02.00060

Set of parts subject to wear pump
for: Pump EVE-OG

Size: 25-40

Accessories



MSS-K 2.5-4A

Part no. 10.04.04.00120

Motor-protection switch with housing

Current range: 2.5 ... 4.0 A

Actuation: Rotary switch

Colour: grey

Protection: IP 65



DRM 40 P1 H

Part no. 10.07.02.00050

Pressure manometer for analogue measurement and
monitoring of the pressure

External diameter D: 40 mm

Measuring range: 0.0 ... 1.0 bar

Shape: Connection at rear

Pressure inlet: G3/4-M

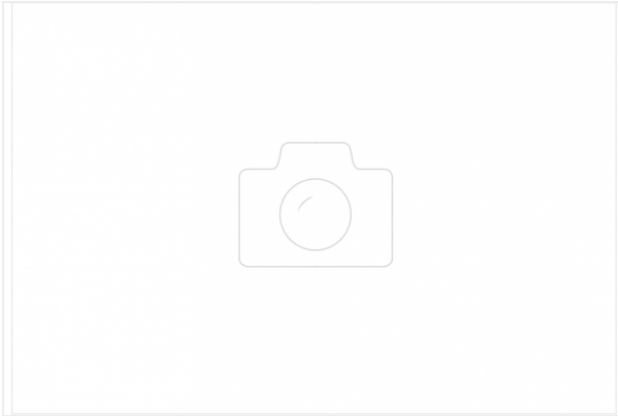

OEL EVE-OG 1L ANDEROL 555

Part no. 27.02.01.00055

Oil

for: Pump_EVE-OG

Volume: 1 l