

# Vacuum pump EVE-OG 25 AC3 F

Part no.: 10.03.02.00020

<https://www.schmalz.com/10.03.02.00020>



Homepage > Vacuum Technology for Automation > Vacuum Components > Vacuum Generators > Vacuum Pumps > Oil-Lubricated Vacuum Pumps EVE-OG > EVE-OG 25 AC3 F

## Oil-lubricated pump for maximum vacuum levels, requires little maintenance



Current type: 3-phase AC  
with: Filter  
Suction rate (50 Hz): 25 m<sup>3</sup>/h  
Rated power (50 Hz): 0.75 kW  
Weight: 34.5 kg

### Design Data

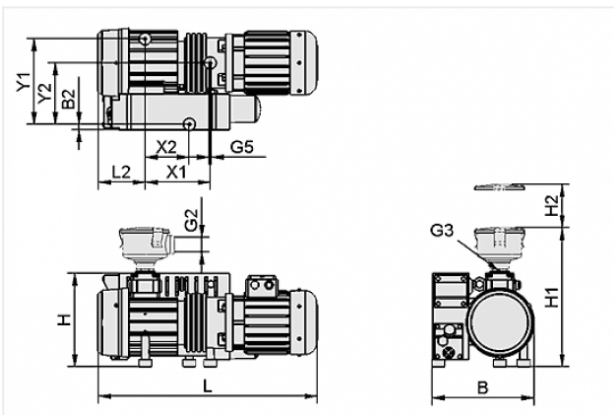

Attribute	Value
B	284 mm
B2	17 mm
G2	G3/4"-F
G3	G1-1/4"-F
G5	M8-F
H	260 mm
H1	380 mm
H2	75 mm
L	568 mm
L2	131 mm
X1	159 mm
X2	120 mm
Y1	238 mm

### Contact to Schmalz

J. Schmalz GmbH | Johannes-Schmalz-Straße, 72293 Glatten, Deutschland | +49 7443 2403-102 | [customercenter@schmalz.de](mailto:customercenter@schmalz.de)

Attribute	Value
Y2	171 mm

## Technical Data

Attribute	Value
Suction rate (50 Hz)	25 m <sup>3</sup> /h
Rated power (50 Hz)	0.75 kW
Weight	34.5 kg
Current type	AC3

## Accessories



### VST EVE-OG-10-16C

Part no. 10.03.02.00075

Set of parts subject to wear pump

for: Pump\_EVE-OG

Size: 10-16C



**OEL EVE-OG 1L ANDEROL 555**

Part no. 27.02.01.00055

Oil

for: Pump\_EVE-OG

Volume: 1 l