

Vacuum pump EVE-OG 16 AC3 F

Part no.: 10.03.02.00083

<https://www.schmalz.com/10.03.02.00083>



Homepage > Vacuum Technology for Automation > Vacuum Components > Vacuum Generators > Vacuum Pumps > Oil-Lubricated Vacuum Pumps EVE-OG > EVE-OG 16 AC3 F

Oil-lubricated pump for maximum vacuum levels, requires little maintenance



Current type: 3-phase AC
 Noise level: 53 dB
 with: Filter
 Voltage (50Hz): 230/400V AC
 Voltage (60Hz): 230/400V AC
 Suction rate (50Hz): 16 m³/h
 Suction rate (60Hz): 19 m³/h
 Rated power (50Hz): 0.55 kW
 Weight: 19 kg

Design Data

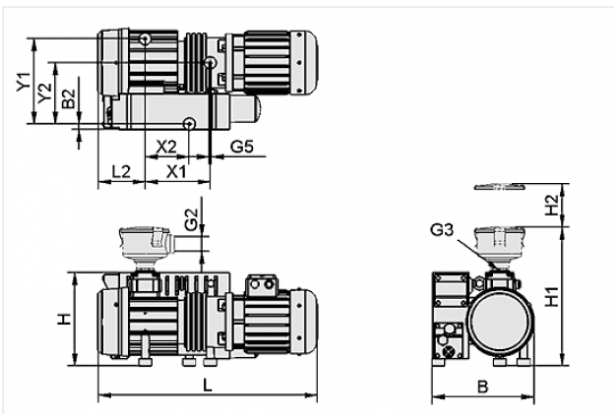

Attribute	Value
B	212 mm
B2	26 mm
G2	G3/4"-F
G3	G3/4"-F
G5	M8-F
H	234 mm
H1	320 mm
H2	70 mm
L	422 mm
L2	63 mm
X1	176 mm
Y1	111 mm

Contact to Schmalz

J. Schmalz GmbH | Johannes-Schmalz-Straße, 72293 Glatten, Deutschland | +49 7443 2403-102 | customercenter@schmalz.de

Technical Data

Attribute	Value
Vacuum (max)	-980 mbar
Vacuum (max)	-28.939 inHg
Suction rate (50 Hz)	16 m ³ /h
Voltage (50 Hz)	230/400V AC
Rated power (50 Hz)	0.55 kW
Noise level (50 Hz)	53 dB
Weight	19 kg
Protection	IP 54
Current type	AC3

Accessories



DRM 40 P1 H

Part no. 10.07.02.00050

Pressure manometer for analogue measurement and monitoring of the pressure

External diameter D: 40 mm

Measuring range: 0.0 ... 1.0 bar

Shape: Connection at rear

Pressure inlet: G3/4-M



OEL EVE-OG 1L ANDEROL 555

Part no. 27.02.01.00055

Oil

for: Pump_EVE-OG

Volume: 1 l