

Vacuum pump

EVE-TR 250 AC3/S070 F IE2

<https://www.schmalz.com/10.03.01.00269>



Part no.: 10.03.01.00269

Homepage > Vacuum Technology for Automation > Vacuum Components > Vacuum Generators > Vacuum Pumps > Dry-Running Vacuum Pumps
EVE-TR > EVE-TR 250 AC3/S070 F IE2

Oil-free pump with constant suction rate, robust, requires little maintenance



Current type: 3-phase AC
 Noise level (50 Hz): 77 dB
 Voltage (50 Hz):
 D200V/Y350V ±10% (w/oIE2)
 Voltage (60 Hz): D220V/Y380-400V ±10%
 Voltage (60 Hz-opt):
 D200V/Y350V ±10% (w/oIE2)
 with: Filter
 Suction rate (50 Hz): 244 m³/h
 Suction rate (60 Hz): 286 m³/h
 Vacuum (50Hz): -800 mbar
 Permission: IE2
 Rated power (50 Hz): 5.5 kW
 Rated power (60 Hz): 6.6 kW
 Weight: 222 kg

Design Data

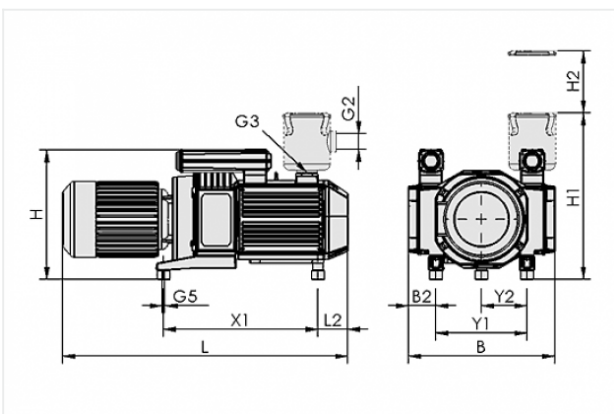

Attribute	Value
B	644 mm
B2	116 mm
G3	G2-1/2"-F
G5	M10-F
H	530 mm
L	1059 mm
L2	123.8 mm
X1	645 mm
Y1	380 mm

Contact to Schmalz

J. Schmalz GmbH | Johannes-Schmalz-Straße, 72293 Glatten, Deutschland | +49 7443 2403-102 | customercenter@schmalz.de

Attribute	Value
Y2	190 mm

Technical Data

Attribute	Value
Suction rate (50 Hz)	244 m ³ /h
Suction rate (60 Hz)	286 m ³ /h
Voltage (50 Hz)	D200V/Y350V ±10% (w/oIE2)
Voltage (60 Hz)	D220V/Y380-400V ±10%
Rated power (50 Hz)	5.5 kW
Rated power (60 Hz)	6.6 kW
Current type	AC3
Noise level (50 Hz)	77 dB
Weight	222 kg
Protection	IP 55

Spare Parts



VST EVE-TR-250

Part no. 10.03.01.00299

Set of parts subject to wear pump

for: Pump EVE-TR

Size: 250

contains: Brush slide/Filter

