

# Vacuum pump

## EVE-TR 80 AC3/S070 F IE2

<https://www.schmalz.com/10.03.01.00254>



Part no.: 10.03.01.00254

Homepage > Vacuum Technology for Automation > Vacuum Components > Vacuum Generators > Vacuum Pumps > Dry-Running Vacuum Pumps  
EVE-TR > EVE-TR 80 AC3/S070 F IE2

### Oil-free pump with constant suction rate, robust, requires little maintenance



Current type: 3-phase AC  
 Noise level (50 Hz): 72 dB  
 Voltage (50 Hz):  
 D200V/Y350V ±10% (w/oIE2)  
 Voltage (60 Hz): D220V/Y380-400V ±10%  
 Voltage (60 Hz-opt):  
 D200V/Y350V ±10% (w/oIE2)  
 with: Filter  
 Suction rate (50 Hz): 67 m³/h  
 Suction rate (60 Hz): 78.5 m³/h  
 Vacuum (50Hz): -900 mbar  
 Permission: IE2  
 Rated power (50 Hz): 2.4 kW  
 Rated power (60 Hz): 3 kW  
 Weight: 78 kg

### Design Data

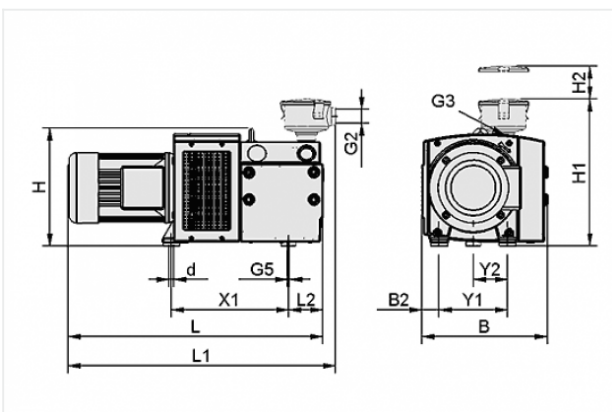

Attribute	Value
B	353 mm
B2	48 mm
d	12 mm
G2	G1-1/4"-F
G3	G1"-F
G5	M8-F
H	328 mm
H1	420 mm
H2	75 mm

### Contact to Schmalz

J. Schmalz GmbH | Johannes-Schmalz-Straße, 72293 Glatten, Deutschland | +49 7443 2403-102 | [customercenter@schmalz.de](mailto:customercenter@schmalz.de)

Attribute	Value
L	709 mm
L1	745 mm
L2	96 mm
X1	326 mm
Y1	190 mm
Y2	95 mm

---

## Technical Data

Attribute	Value
Suction rate (50 Hz)	67 m <sup>3</sup> /h
Suction rate (60 Hz)	78.5 m <sup>3</sup> /h
Voltage (50 Hz)	D200V/Y350V $\pm 10\%$ (w/oIE2)
Voltage (60 Hz)	D220V/Y380-400V $\pm 10\%$
Rated power (50 Hz)	2.4 kW
Rated power (60 Hz)	3 kW
Current type	AC3
Noise level (50 Hz)	72 dB
Weight	78 kg
Protection	IP 55

---

---