

Vacuum pump EVE-TR 40 AC3 F

Part no.: 10.03.01.00148

<https://www.schmalz.com/10.03.01.00148>



Homepage > Vacuum Technology for Automation > Vacuum Components > Vacuum Generators > Vacuum Pumps > Dry-Running Vacuum Pumps
EVE-TR > EVE-TR 40 AC3 F

Oil-free pump with constant suction rate, robust, requires little maintenance



Current type: 3-phase AC
 Noise level (50 Hz): 67 dB
 Voltage (50 Hz): 190-255V or 330-440V
 Voltage (60 Hz): 190-290V or 330-500V
 with: Filter
 Suction rate (50 Hz): 40 m³/h
 Suction rate (60 Hz): 48 m³/h
 Vacuum (50Hz): -850 mbar
 Rated power (50 Hz): 1.25 kW
 Rated power (60 Hz): 1.5 kW
 Weight: 40 kg

Design Data

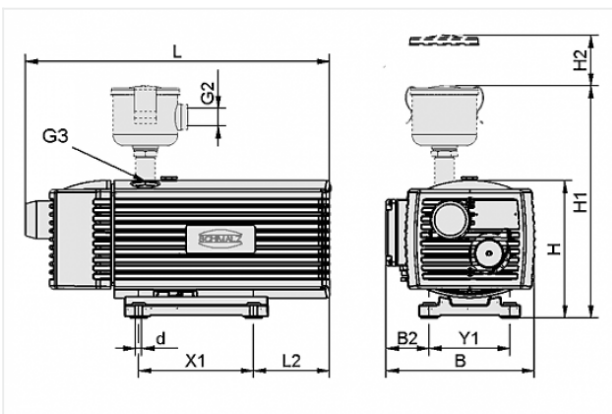

Attribute	Value
B	280 mm
B2	51 mm
d	7 mm
G2	G1-1/4"-F
G3	G3/4"-F
H	293 mm
H1	425 mm
H2	70 mm
L	572 mm
L2	131 mm
X1	220 mm

Contact to Schmalz

J. Schmalz GmbH | Johannes-Schmalz-Straße, 72293 Glatten, Deutschland | +49 7443 2403-102 | customercenter@schmalz.de

Attribute	Value
Y1	190 mm

Technical Data

Attribute	Value
Suction rate (50 Hz)	40 m ³ /h
Suction rate (60 Hz)	48 m ³ /h
Voltage (50 Hz)	190-255V or 330-440V
Voltage (60 Hz)	190-290V or 330-500V
Rated power (50 Hz)	1.25 kW
Rated power (60 Hz)	1.5 kW
Current type	AC3
Noise level (50 Hz)	67 dB
Weight	40 kg
Protection	IP 55

Spare Parts



FILT-EINS EVE-TR-25-40

Part no. 10.03.01.00029

Filter insert (round)

for: Pump EVE-TR

Size: 25-40

Contact to Schmalz

**FILT-EINS 3 98x70 PAP STF-1-1/4-IGN**

Part no. 10.07.01.00018

Filter insert (round)

Filter pore size: 3 µm

External diameter D: 98 mm

Length L: 70 mm

Filter material: Paper

for: Filters STF

Size: 1-1/4-IGN

**VST EVE-TR-40**

Part no. 10.03.01.00135

Set of parts subject to wear pump

for: Pump EVE-TR

Size: 40

contains: Brush slide kit

and: Filter

Accessories**MSS-K 4-6.3A**

Part no. 10.04.04.00121

Motor-protection switch with housing

Current range: 4.0 ... 6.3 A

Actuation: Rotary switch

Colour: grey

Protection: IP 65

**VBV -950...0 G1-AG EVE 10-40**

Part no. 10.03.01.00136

Vacuum valve for limiting the maximum vacuum pressure

Vacuum range: -950 ... 0 mbar

Thread G1: G1"-M

Length L: 53.5 mm

for: Pump EVE

Size: 10-40

**VST EVE-TR-40**

Part no. 10.03.01.00135

Set of parts subject to wear pump

for: Pump EVE-TR

Size: 40

contains: Brush slide kit

and: Filter

**SBB-650x575x565-ST-VZ**

Part no. 10.04.04.00117

Silencer box for reduction of the noise level

Material: Steel

Surface: galvanised

Length L: 650 mm

Width B: 575 mm

Height H: 565 mm