

# Vacuum pump EVE-TR 25 AC3 F

Part no.: 10.03.01.00147

<https://www.schmalz.com/10.03.01.00147>



Homepage > Vacuum Technology for Automation > Vacuum Components > Vacuum Generators > Vacuum Pumps > Dry-Running Vacuum Pumps  
EVE-TR > EVE-TR 25 AC3 F

## Oil-free pump with constant suction rate, robust, requires little maintenance



Current type: 3-phase AC  
 Noise level (50 Hz): 62 dB  
 Voltage (50 Hz):  
 190-255V/330-440V AC3  
 Voltage (60 Hz):  
 190-290V/330-500V AC3  
 with: Filter  
 Suction rate (50 Hz): 25 m<sup>3</sup>/h  
 Suction rate (60 Hz): 30 m<sup>3</sup>/h  
 Vacuum (50Hz): -850 mbar  
 Rated power (50 Hz): 0.75 kW  
 Rated power (60 Hz): 0.9 kW  
 Weight: 27 kg

### Design Data

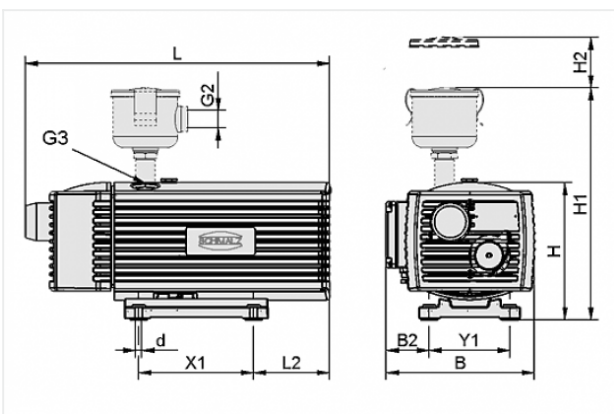

Attribute	Value
B	260 mm
B2	40 mm
d	7 mm
G2	G3/4"-F
G3	G3/4"-F
H	293 mm
H1	380 mm
H2	70 mm
L	505 mm
L2	96 mm

### Contact to Schmalz

J. Schmalz GmbH | Johannes-Schmalz-Straße, 72293 Glatten, Deutschland | +49 7443 2403-102 | [customercenter@schmalz.de](mailto:customercenter@schmalz.de)



Attribute	Value
X1	220 mm
Y1	208 mm

---

## Technical Data

Attribute	Value
Suction rate (50 Hz)	25 m <sup>3</sup> /h
Suction rate (60 Hz)	30 m <sup>3</sup> /h
Voltage (50 Hz)	190-255V/330-440V AC3
Voltage (60 Hz)	190-290V/330-500V AC3
Rated power (50 Hz)	0.75 kW
Rated power (60 Hz)	0.9 kW
Current type	AC3
Noise level (50 Hz)	62 dB
Weight	27 kg
Protection	IP 55

---

## Spare Parts

### Contact to Schmalz



**FILT-EINS EVE-TR-25-40**

Part no. 10.03.01.00029

Filter insert (round)

for: Pump EVE-TR

Size: 25-40



**FILT-EINS 3 65x70 PAP STF-3/4-IG**

Part no. 10.07.01.00017

Filter insert (round)

Filter pore size: 3 µm

External diameter D: 65 mm

Length L: 70 mm

Filter material: Paper

for: Filters STF

Size: 3/4-IG



**VST EVE-TR-25**

Part no. 10.03.01.00134

Set of parts subject to wear pump

for: Pump EVE-TR

Size: 25

contains: Brush slide kit

and: Filter

**Accessories**

**Contact to Schmalz**

J. Schmalz GmbH | Johannes-Schmalz-Straße, 72293 Glatten, Deutschland | +49 7443 2403-102 |  
customercenter@schmalz.de

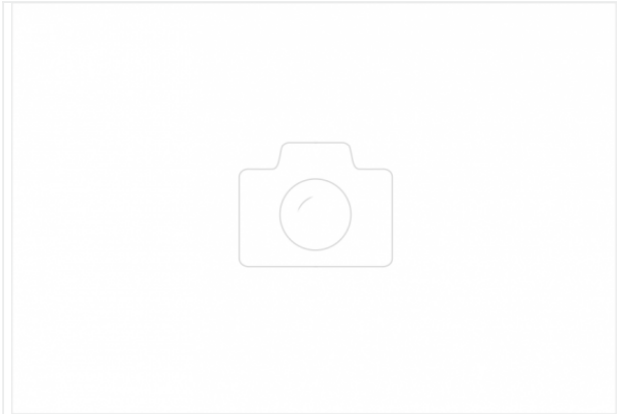

**VBV -950...0 G1-AG EVE 10-40**

Part no. 10.03.01.00136

Vacuum valve for limiting the maximum vacuum pressure

Vacuum range: -950 ... 0 mbar

Thread G1: G1"-M

Length L: 53.5 mm

for: Pump EVE

Size: 10-40



**MSS-K 1.6-2.5A**

Part no. 10.04.04.00119

Motor-protection switch with housing

Current range: 1.6 ... 2.5 A

Actuation: Rotary switch

Colour: grey

Protection: IP 65



**SBB-650x575x565-ST-VZ**

Part no. 10.04.04.00117

Silencer box for reduction of the noise level

Material: Steel

Surface: galvanised

Length L: 650 mm

Width B: 575 mm

Height H: 565 mm