

Vacuum pump EVE-TR 16 AC3 F

Part no.: 10.03.01.00145

<https://www.schmalz.com/10.03.01.00145>



Homepage > Vacuum Technology for Automation > Vacuum Components > Vacuum Generators > Vacuum Pumps > Dry-Running Vacuum Pumps
EVE-TR > EVE-TR 16 AC3 F

Oil-free pump with constant suction rate, robust, requires little maintenance



Current type: 3-phase AC
Noise level (50 Hz): 61 dB
Voltage (50 Hz): 175-260V or 300-450V
Voltage (60 Hz): 200-300V or 350-520V
with: Filter
Suction rate (50 Hz): 16 m³/h
Suction rate (60 Hz): 19 m³/h
Vacuum (50Hz): -850 mbar
Rated power (50 Hz): 0.55 kW
Rated power (60 Hz): 0.7 kW
Weight: 23.4 kg

Design Data

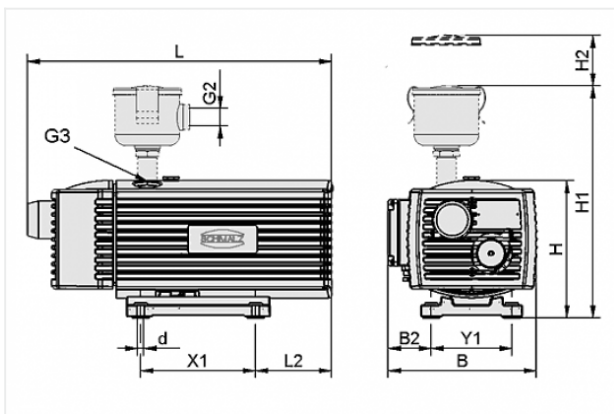

Attribute	Value
B	231 mm
B2	66 mm
d	7 mm
G2	G3/4-F
G3	G1/2-F
H	214 mm
H1	345 mm
H2	70 mm
L	452 mm
L2	73 mm
X1	202 mm

Contact to Schmalz

J. Schmalz GmbH | Johannes-Schmalz-Straße, 72293 Glatten, Deutschland | +49 7443 2403-102 |
customercenter@schmalz.de

Attribute	Value
Y1	125 mm

Technical Data

Attribute	Value
Suction rate (50 Hz)	16 m ³ /h
Suction rate (60 Hz)	19 m ³ /h
Voltage (50 Hz)	175-260V or 300-450V
Voltage (60 Hz)	200-300V or 350-520V
Rated power (50 Hz)	0.55 kW
Rated power (60 Hz)	0.7 kW
Current type	AC3
Noise level (50 Hz)	61 dB
Weight	23.4 kg
Protection	IP 54

Spare Parts



FILT-EINS 3 65x70 PAP STF-3/4-IG

Part no. 10.07.01.00017

Filter insert (round)

Filter pore size: 3 µm

External diameter D: 65 mm

Length L: 70 mm

Filter material: Paper

for: Filters STF

Size: 3/4-IG



FILT-EINS EVE-16-25
Part no. 10.03.01.00022
Filter insert (round)
for: Pump
Size: 16-25



VST EVE-TR-16
Part no. 10.03.01.00133
Set of parts subject to wear pump
for: Pump EVE-TR
Size: 16
contains: Brush slide kit
and: Filter

Accessories



MSS-K 1.6-2.5A
Part no. 10.04.04.00119
Motor-protection switch with housing
Current range: 1.6 ... 2.5 A
Actuation: Rotary switch
Colour: grey
Protection: IP 65



VBV -950...0 G1-AG EVE 10-40

Part no. 10.03.01.00136

Vacuum valve for limiting the maximum vacuum pressure

Vacuum range: -950 ... 0 mbar

Thread G1: G1"-M

Length L: 53.5 mm

for: Pump EVE

Size: 10-40



SBB-650x575x565-ST-VZ

Part no. 10.04.04.00117

Silencer box for reduction of the noise level

Material: Steel

Surface: galvanised

Length L: 650 mm

Width B: 575 mm

Height H: 565 mm