

Vacuum pump EVE-TR 16 AC3

Part no.: 10.03.01.00139

<https://www.schmalz.com/10.03.01.00139>



Homepage > Vacuum Technology for Automation > Vacuum Components > Vacuum Generators > Vacuum Pumps > Dry-Running Vacuum Pumps
EVE-TR > EVE-TR 16 AC3

Oil-free pump with constant suction rate, robust, requires little maintenance



Current type: 3-phase AC
Noise level (50 Hz): 61 dB
Voltage (50 Hz): 175-260V or 300-450V
Voltage (60 Hz): 200-300V or 350-520V
Suction rate (50 Hz): 16 m³/h
Suction rate (60 Hz): 19 m³/h
Vacuum (50Hz): -850 mbar
Rated power (50 Hz): 0.55 kW
Rated power (60 Hz): 0.7 kW
Weight: 22.4 kg

Design Data

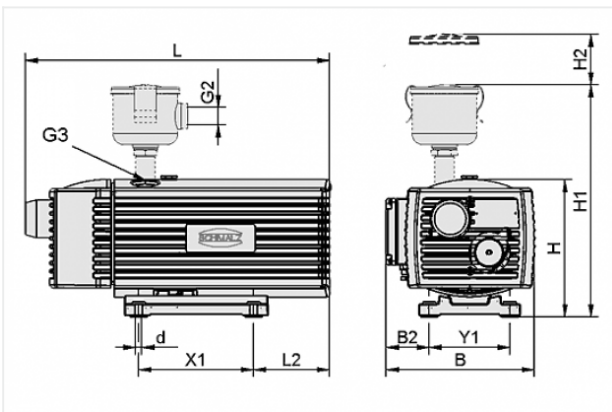

Attribute	Value
-----------	-------

B	231 mm
---	--------

B2	66 mm
----	-------

d	7 mm
---	------

G3	G1/2-F
----	--------

H	211 mm
---	--------

L	452 mm
---	--------

L2	73 mm
----	-------

X1	202 mm
----	--------

Y1	125 mm
----	--------

Contact to Schmalz

J. Schmalz GmbH | Johannes-Schmalz-Straße, 72293 Glatten, Deutschland | +49 7443 2403-102 | customercenter@schmalz.de

Technical Data

Attribute	Value
Suction rate (50 Hz)	16 m ³ /h
Suction rate (60 Hz)	19 m ³ /h
Voltage (50 Hz)	175-260V or 300-450V
Voltage (60 Hz)	200-300V or 350-520V
Rated power (50 Hz)	0.55 kW
Rated power (60 Hz)	0.7 kW
Current type	AC3
Noise level (50 Hz)	61 dB
Weight	22.4 kg
Protection	IP 54

Spare Parts



FILT-EINS EVE-16-25
Part no. 10.03.01.00022
Filter insert (round)
for: Pump
Size: 16-25

Accessories

Contact to Schmalz



MSS-K 1.6-2.5A

Part no. 10.04.04.00119

Motor-protection switch with housing

Current range: 1.6 ... 2.5 A

Actuation: Rotary switch

Colour: grey

Protection: IP 65

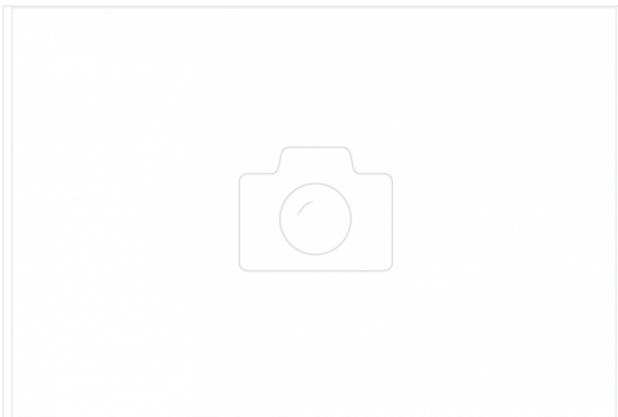

VBV -950...0 G1-AG EVE 10-40

Part no. 10.03.01.00136

Vacuum valve for limiting the maximum vacuum pressure

Vacuum range: -950 ... 0 mbar

Thread G1: G1"-M

Length L: 53.5 mm

for: Pump EVE

Size: 10-40

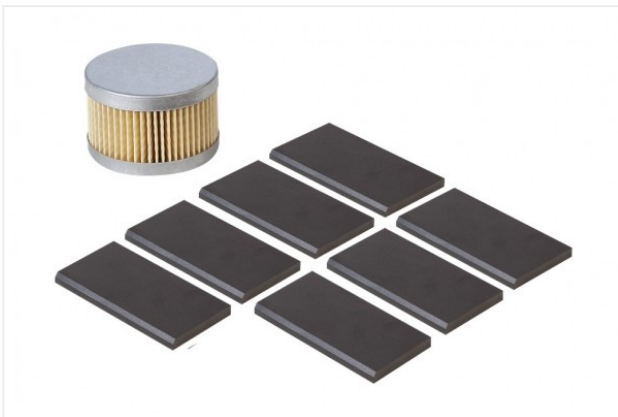

VST EVE-TR-16

Part no. 10.03.01.00133

Set of parts subject to wear pump

for: Pump EVE-TR

Size: 16

contains: Brush slide kit

and: Filter



SBB-650x575x565-ST-VZ

Part no. 10.04.04.00117

Silencer box for reduction of the noise level

Material: Steel

Surface: galvanised

Length L: 650 mm

Width B: 575 mm

Height H: 565 mm