

Vacuum pump EVE-TR 10 AC3 F

Part no.: 10.03.01.00143

<https://www.schmalz.com/10.03.01.00143>



Homepage > Vacuum Technology for Automation > Vacuum Components > Vacuum Generators > Vacuum Pumps > Dry-Running Vacuum Pumps
EVE-TR > EVE-TR 10 AC3 F

Oil-free pump with constant suction rate, robust, requires little maintenance



Current type: 3-phase AC
Noise level (50 Hz): 60 dB
Voltage (50 Hz): 175-260V or 300-450V
Voltage (60 Hz): 200-300V or 350-520V
with: Filter
Suction rate (50 Hz): 10 m³/h
Suction rate (60 Hz): 12 m³/h
Vacuum (50Hz): -850 mbar
Rated power (50 Hz): 0.37 kW
Rated power (60 Hz): 0.45 kW
Weight: 17 kg

Design Data

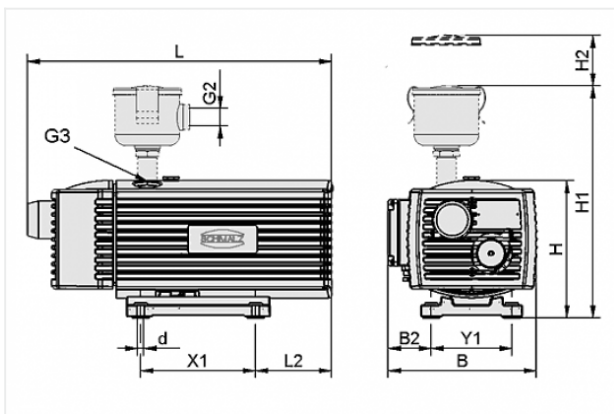

Attribute	Value
B	206 mm
B2	60 mm
d	7 mm
G2	G3/4-F
G3	G1/2-F
H	198 mm
H1	325 mm
H2	70 mm
L	429 mm
L2	106 mm
X1	160 mm

Contact to Schmalz

J. Schmalz GmbH | Johannes-Schmalz-Straße, 72293 Glatten, Deutschland | +49 7443 2403-102 |
customercenter@schmalz.de

Attribute	Value
Y1	112 mm

Technical Data

Attribute	Value
Suction rate (50 Hz)	10 m ³ /h
Suction rate (60 Hz)	12 m ³ /h
Voltage (50 Hz)	175-260V or 300-450V
Voltage (60 Hz)	200-300V or 350-520V
Rated power (50 Hz)	0.37 kW
Rated power (60 Hz)	0.45 kW
Current type	AC3
Noise level (50 Hz)	60 dB
Weight	17 kg
Protection	IP 54

Spare Parts



FILT-EINS 39x40 EVE-10B+C-TR10

Part no. 10.03.01.00021

Filter insert (round)

External diameter: 39 mm

Length: 40 mm

for: Pump

Size: 10B+C-TR10



FILT-EINS 3 65x70 PAP STF-3/4-IG

Part no. 10.07.01.00017

Filter insert (round)

Filter pore size: 3 µm

External diameter D: 65 mm

Length L: 70 mm

Filter material: Paper

for: Filters STF

Size: 3/4-IG



VST EVE-TR-10

Part no. 10.03.01.00132

Set of parts subject to wear pump

for: Pump EVE-TR

Size: 10

contains: Brush slide kit

and: Filter

Accessories



MSS-K 1-1.6A

Part no. 10.04.04.00118

Motor-protection switch with housing

Current range: 1.0 ... 1.6 A

Actuation: Rotary switch

Colour: grey

Protection: IP 65



VBV -950...0 G1-AG EVE 10-40

Part no. 10.03.01.00136

Vacuum valve for limiting the maximum vacuum pressure

Vacuum range: -950 ... 0 mbar

Thread G1: G1"-M

Length L: 53.5 mm

for: Pump EVE

Size: 10-40



VST EVE-TR-10

Part no. 10.03.01.00132

Set of parts subject to wear pump

for: Pump EVE-TR

Size: 10

contains: Brush slide kit

and: Filter