

# Vacuum pump EVE-TR 10 AC3

Part no.: 10.03.01.00137

<https://www.schmalz.com/10.03.01.00137>



Homepage > Vacuum Technology for Automation > Vacuum Components > Vacuum Generators > Vacuum Pumps > Dry-Running Vacuum Pumps  
EVE-TR > EVE-TR 10 AC3

## Oil-free pump with constant suction rate, robust, requires little maintenance



Current type: 3-phase AC  
Noise level (50 Hz): 60 dB  
Voltage (50 Hz): 175-260V or 300-450V  
Voltage (60 Hz): 200-300V or 350-520V  
Suction rate (50 Hz): 10 m<sup>3</sup>/h  
Suction rate (60 Hz): 12 m<sup>3</sup>/h  
Vacuum (50Hz): -850 mbar  
Rated power (50 Hz): 0.37 kW  
Rated power (60 Hz): 0.45 kW  
Weight: 16 kg

### Design Data

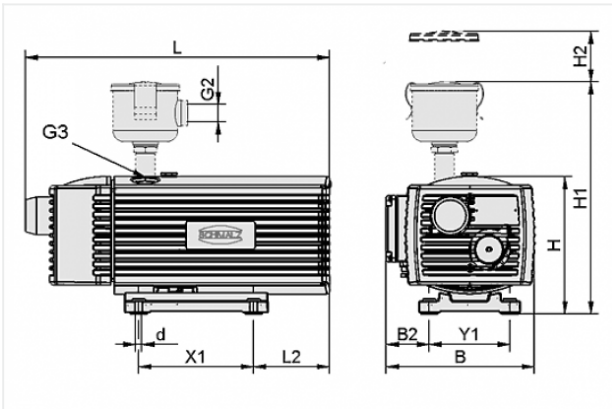

Attribute	Value
-----------	-------

B	206 mm
---	--------

B2	60 mm
----	-------

d	7 mm
---	------

G3	G1/2-F
----	--------

H	195 mm
---	--------

L	429 mm
---	--------

L2	106 mm
----	--------

X1	160 mm
----	--------

Y1	112 mm
----	--------

### Contact to Schmalz

J. Schmalz GmbH | Johannes-Schmalz-Straße, 72293 Glatten, Deutschland | +49 7443 2403-102 |  
customercenter@schmalz.de

## Technical Data

Attribute	Value
Suction rate (50 Hz)	10 m <sup>3</sup> /h
Suction rate (60 Hz)	12 m <sup>3</sup> /h
Voltage (50 Hz)	175-260V or 300-450V
Voltage (60 Hz)	200-300V or 350-520V
Rated power (50 Hz)	0.37 kW
Rated power (60 Hz)	0.45 kW
Current type	AC3
Noise level (50 Hz)	60 dB
Weight	16 kg
Protection	IP 54

## Spare Parts



### **FILT-EINS 39x40 EVE-10B+C-TR10**

Part no. 10.03.01.00021

Filter insert (round)

External diameter: 39 mm

Length: 40 mm

for: Pump

Size: 10B+C-TR10



**FILT-EINS 3 65x70 PAP STF-3/4-IG**

Part no. 10.07.01.00017

Filter insert (round)

Filter pore size: 3 µm

External diameter D: 65 mm

Length L: 70 mm

Filter material: Paper

for: Filters STF

Size: 3/4-IG



**VST EVE-TR-10**

Part no. 10.03.01.00132

Set of parts subject to wear pump

for: Pump EVE-TR

Size: 10

contains: Brush slide kit

and: Filter

## Accessories



**MSS-K 1-1.6A**

Part no. 10.04.04.00118

Motor-protection switch with housing

Current range: 1.0 ... 1.6 A

Actuation: Rotary switch

Colour: grey

Protection: IP 65



**VBV -950...0 G1-AG EVE 10-40**

Part no. 10.03.01.00136

Vacuum valve for limiting the maximum vacuum pressure

Vacuum range: -950 ... 0 mbar

Thread G1: G1"-M

Length L: 53.5 mm

for: Pump EVE

Size: 10-40



**VST EVE-TR-10**

Part no. 10.03.01.00132

Set of parts subject to wear pump

for: Pump EVE-TR

Size: 10

contains: Brush slide kit

and: Filter