

Schmalz X-Pump

SXMPi 25 NO H 2xM12-5

<https://www.schmalz.com/10.02.02.03802>



Part no.: 10.02.02.03802

Homepage > Vacuum Technology for Automation > Vacuum Components > Vacuum Generators > Compact Ejectors > Compact Ejectors X-Pump
 SXPi / SXMPi with IO-Link > SXMPi 25 NO H 2xM12-5

Compact ejector with Condition Monitoring, power blow-off function and pneu. air-saving function



Nozzle size: 2,5 mm
 Control: Normally open
 Pneum. Connection: Horizontal
 Electrical connection:
 2xConnect M12, 5+5 pol
 Suction rate (max): 185 l/min
 Air consumption (during evac.):
 290 l/min
 Communication: IO-Link (Class A)
 Vacuum (max): -850 mbar
 Noise level (free): 67 dB
 Protection: IP 65

Design Data

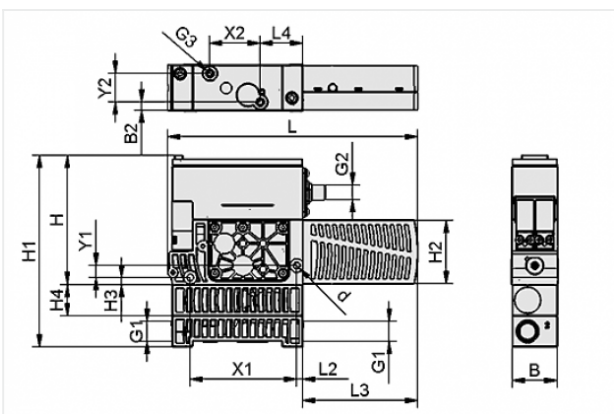

Attribute	Value
B	39 mm
B2	6.8 mm
d	5.5 mm
G1	G3/8"-F
G2	M12x1-M
G3	M5-F
H	160 mm
H1	160 mm
H2	54 mm
H3	6 mm

Contact to Schmalz

J. Schmalz GmbH | Johannes-Schmalz-Straße, 72293 Glatten, Deutschland | +49 7443 2403-102 | customercenter@schmalz.de

Attribute	Value
L	210 mm
L2	5 mm
L3	97 mm
L4	35.5 mm
X1	89 mm
X2	42 mm
Y1	10 mm
Y2	24 mm

Technical Data

Attribute	Value
Nozzle size	2.5 mm
Degree of evacuation	85 %
Suction rate (max)	185 l/min
Suction rate (max)	11.1 m ³ /h
Air consumption (during evac.)	290 l/min
Air consumption (during evac.)	17.4 m ³ /h
Air consumption (blow off) (max)	320 l/min
Vacuum (max)	-850 mbar
Noise level (free)	67 dB
Pressure range (operating pressure)	3.0 ... 6.0 bar
Int. hose diameter (recom.) comp.-air	8 mm
Int. hose diameter (recom.) vacuum side	9 mm
Weight	0.91 kg
Ambient temperature	0 ... 50 °C

Contact to Schmalz

Attribute	Value
Pressure range (operating pressure)	43.5 ... 87.0 psi
Suction rate (max)	6.533 cfm
Air consumption (during evac.)	10.241 cfm
Vacuum (max)	-25.1 inHg
Product family	SXMPi

Note:

- The supply voltage for vacuum switches and solenoid valves is 24V DC
- Air consumption: At optimal operating pressure
- Hose diameter: For max. length 2 m

Spare Parts



SD 96x54x40 SXPi/SXMPi

Part no. 10.02.02.02124

Silencer for vacuum generators

Length L: 96 mm

Width B: 54 mm

Height H: 40 mm

for: Compact ejectors SXPi/SXMPi

Accessories



ASK B-M12-5 5000

Part no. 21.04.05.00080

Connection cable

Interface Connection cable:

Fem connect M12, 5 pol

Cable length: 5000 mm

Material: PUR-Cable

Contact to Schmalz

