

Schmalz X-Pump

SXPi 25 NO H M12-8

<https://www.schmalz.com/10.02.02.03776>



Part no.: 10.02.02.03776

Homepage > Vacuum Technology for Automation > Vacuum Components > Vacuum Generators > Compact Ejectors > Compact Ejectors X-Pump
SXPi / SXMPi with IO-Link > SXPi 25 NO H M12-8

Compact ejector with Condition Monitoring and air-saving function



Nozzle size: 2,5 mm
Control: Normally open
Pneum. Connection: Horizontal
Electrical connection:
Male connect M12, 8 pol
Communication: IO-Link (Class A)
Suction rate (max): 185 l/min
Air consumption (during evac.):
290 l/min
Vacuum (max): 850 mbar
Noise level (free): 67 dB
Protection: IP 65

Design Data

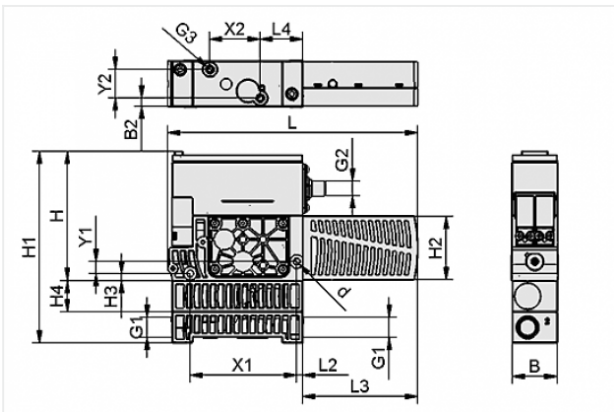

Attribute	Value
B	39 mm
B2	6.8 mm
d	5.5 mm
G1	G3/8"-F
G2	M12x1-M
G3	M5-F
H	108 mm
H1	134 mm
H2	54 mm
H3	6 mm
L	210 mm

Contact to Schmalz

J. Schmalz GmbH | Johannes-Schmalz-Straße, 72293 Glatten, Deutschland | +49 7443 2403-102 |
customercenter@schmalz.de

Attribute	Value
L2	5 mm
L3	97 mm
L4	35.5 mm
X1	89 mm
X2	42 mm
Y1	10 mm
Y2	24 mm

Technical Data

Attribute	Value
Nozzle size	2.5 mm
Degree of evacuation	85 %
Suction rate (max)	185 l/min
Suction rate (max)	11.1 m ³ /h
Air consumption (during evac.)	290 l/min
Air consumption (during evac.)	17.4 m ³ /h
Air consumption (blow off) (max)	200 l/min
Vacuum (max)	850 mbar
Noise level (free)	67 dB
Pressure range (operating pressure)	3.0 ... 6.0 bar
Int. hose diameter (recom.) comp.-air	8 mm
Int. hose diameter (recom.) vacuum side	9 mm
Weight	0.77 kg
Ambient temperature	0 ... 50 °C
Pressure range (operating pressure)	43.5 ... 87.0 psi

Contact to Schmalz

Attribute	Value
Suction rate (max)	6.533 cfm
Air consumption (during evac.)	10.241 cfm
Air consumption (blow off)	7.062 cfm
Vacuum (max)	25.1 inHg
Product family	SXPi

Note:

- The supply voltage for vacuum switches and solenoid valves is 24V DC
- Air consumption: At optimal operating pressure
- Hose diameter: For max. length 2 m

Spare Parts



SD 96x54x40 SXPi/SXMPi

Part no. 10.02.02.02124

Silencer for vacuum generators

Length L: 96 mm

Width B: 54 mm

Height H: 40 mm

for: Compact ejectors SXPi/SXMPi

Accessories



ASK B-M12-8 5000

Part no. 21.04.05.00079

Connection cable

Interface Connection 1:

Fem connect M12, 8 pol

Cable length: 5000 mm

Material: PUR-Cable

