

Basic ejector

SBP HV 3 16 22 S SD

Part no.: 10.02.01.01740

<https://www.schmalz.com/10.02.01.01740>



Homepage > Vacuum Technology for Automation > Vacuum Components > Vacuum Generators > Basic Ejectors > Basic Ejectors SBP-HV/HF > SBP HV 3 16 22 S SD

Basic ejector for universal use



Shape: High vacuum
 Number of stages: 3
 Nozzle size: 1,6 mm
 Size: 22
 with: Silencer
 Degree of evacuation: 90 %
 Pressure optimal: 4 bar
 Suction rate (max): 308.8 l/min
 Air consumption (during evac.):
 103 l/min
 Shape: With safety valve

Design Data

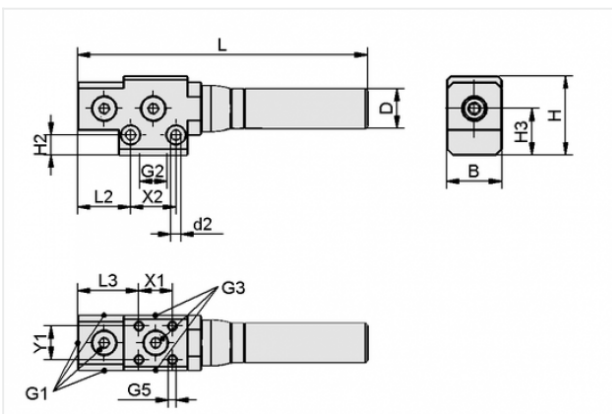

Attribute	Value
B	35 mm
d2	6.4 mm
D	29 mm
G1	G1/4"-F
G2	G3/8"-F
G3	G1/4"-F
G5	M6-F
H	44 mm
H2	9.5 mm
H3	25.5 mm
L	230.5 mm

Contact to Schmalz

J. Schmalz GmbH | Johannes-Schmalz-Straße, 72293 Glatten, Deutschland | +49 7443 2403-102 | customercenter@schmalz.de

Attribute	Value
L2	32.5 mm
L3	34.5 mm
X1	22 mm
X2	26 mm
Y1	22 mm

Technical Data

Attribute	Value
Nozzle diameter	1.6 mm
Number of stages	3
Degree of evacuation	90 %
Suction rate (max)	19 m ³ /h
Suction rate (max)	308.8 l/min
Air consumption (during evac.)	6.34 m ³ /h
Air consumption (during evac.)	103 l/min
Noise level (free)	70 dB
Noise level (workp. gripped)	63 dB
Pressure range (operating pressure)	2.0 ... 6.0 bar
Pressure optimal	4 bar
Int. hose diameter (recom.) comp.-air	6 mm
Int. hose diameter (recom.) vacuum side	12 mm
Weight	295 g
Ambient temperature	0 ... 60 °C
Pressure range (operating pressure)	29.0 ... 87.0 psi
Pressure optimal	58 psi

Contact to Schmalz



Attribute	Value
Suction rate (max)	10.904 cfm
Air consumption (during evac.)	3.637 cfm
