

Basic ejector

SBP HV 3 07 13 S

Part no.: 10.02.01.01722

<https://www.schmalz.com/10.02.01.01722>



Homepage > Vacuum Technology for Automation > Vacuum Components > Vacuum Generators > Basic Ejectors > Basic Ejectors SBP-HV/HF > SBP HV 3 07 13 S

Basic ejector for universal use



Design: High vacuum
 Number of stages: 3
 Nozzle size: 0,7 mm
 Size: 13
 Degree of evacuation: 85 %
 Pressure optimal: 4 bar
 Suction rate (max): 76.8 l/min
 Air consumption (during evac.):
 23.5 l/min
 Design: With safety valve

Design Data

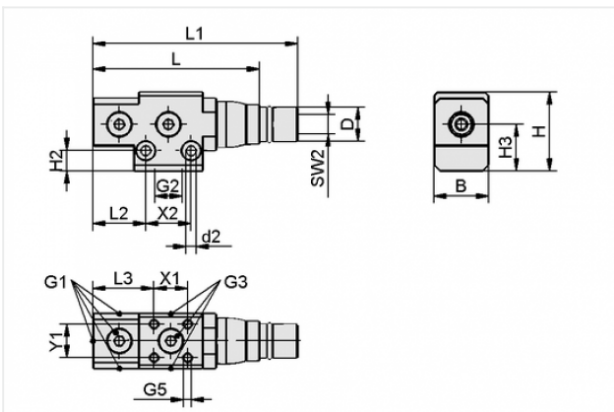

Attribute	Value
B	23 mm
d2	4.2 mm
D	14.2 mm
G1	G1/8"-F
G2	G1/4"-F
G3	G1/8"-F
G5	M4-F
H	33 mm
H2	8.5 mm
H3	19.5 mm
L	88 mm
L1	104 mm

Contact to Schmalz

J. Schmalz GmbH | Johannes-Schmalz-Straße, 72293 Glatten, Deutschland | +49 7443 2403-102 | customercenter@schmalz.de

Attribute	Value
L2	22 mm
L3	25.5 mm
SW2	8 mm
X1	14 mm
X2	19 mm
Y1	14 mm

Technical Data

Attribute	Value
Nozzle diameter	0.7 mm
Number of stages	3
Degree of evacuation	85 %
Suction rate (max)	4.73 m ³ /h
Suction rate (max)	76.8 l/min
Air consumption (during evac.)	1.45 m ³ /h
Air consumption (during evac.)	23.5 l/min
Noise level (free)	70 dB
Noise level (workp. gripped)	61 dB
Pressure range (operating pressure)	2.0 ... 6.0 bar
Pressure optimal	4 bar
Int. hose diameter (recom.) comp.-air	4 mm
Int. hose diameter (recom.) vacuum side	6 mm
Weight	89.6 g
Ambient temperature	0 ... 60 °C
Pressure range (operating pressure)	29.0 ... 87.0 psi

Contact to Schmalz



Attribute	Value
Pressure optimal	58 psi
Suction rate (max)	2.712 cfm
Air consumption (during evac.)	0.829 cfm