

Basic ejector

SBP HF 3 13 22

Part no.: 10.02.01.01726

<https://www.schmalz.com/10.02.01.01726>



Homepage > Vacuum Technology for Automation > Vacuum Components > Vacuum Generators > Basic Ejectors > Basic Ejectors SBP-HV/HF > SBP HF 3 13 22

Basic ejector for universal use



Shape: High Flow
 Number of stages: 3
 Nozzle size: 1,3 mm
 Size: 22
 Degree of evacuation: 61 %
 Pressure optimal: 4 bar
 Suction rate (max): 297.6 l/min
 Air consumption (during evac.):
 74 l/min

Design Data

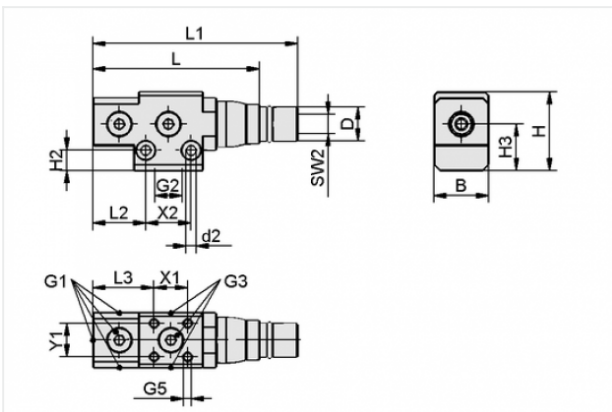

Attribute	Value
B	35 mm
d2	6.4 mm
D	20 mm
G1	G1/4"-F
G2	G3/8"-F
G3	G1/4"-F
G5	M6-F
H	44 mm
H2	9.5 mm
H3	25.5 mm
L	160.5 mm
L1	178.5 mm
L2	32.5 mm

Contact to Schmalz

J. Schmalz GmbH | Johannes-Schmalz-Straße, 72293 Glatten, Deutschland | +49 7443 2403-102 | customercenter@schmalz.de

Attribute	Value
L3	34.5 mm
SW2	14 mm
X1	22 mm
X2	26 mm
Y1	22 mm

Technical Data

Attribute	Value
Nozzle diameter	1.3 mm
Number of stages	3
Degree of evacuation	61 %
Suction rate (max)	18.31 m ³ /h
Suction rate (max)	297.6 l/min
Air consumption (during evac.)	4.55 m ³ /h
Air consumption (during evac.)	74 l/min
Noise level (free)	81 dB
Noise level (workp. gripped)	73 dB
Pressure range (operating pressure)	2.0 ... 6.0 bar
Pressure optimal	4 bar
Int. hose diameter (recom.) comp.-air	6 mm
Int. hose diameter (recom.) vacuum side	12 mm
Weight	280 g
Ambient temperature	0 ... 60 °C
Pressure range (operating pressure)	29.0 ... 87.0 psi
Pressure optimal	58 psi

Contact to Schmalz



Attribute	Value
Suction rate (max)	10.509 cfm
Air consumption (during evac.)	2.613 cfm
