

Basic ejector

SEG 20 LS

<https://www.schmalz.com/10.02.01.00252>



Part no.: 10.02.01.00252

Homepage > Vacuum Technology for Automation > Vacuum Components > Vacuum Generators > Basic Ejectors > Basic Ejectors SEG > SEG 20 LS

Basic ejector with robust housing for universal use



Nozzle size: 2,0 mm
Shape: For high suction capacity
Suction rate (max): 170 l/min
Air consumption (during evac.):
186 l/min

Design Data

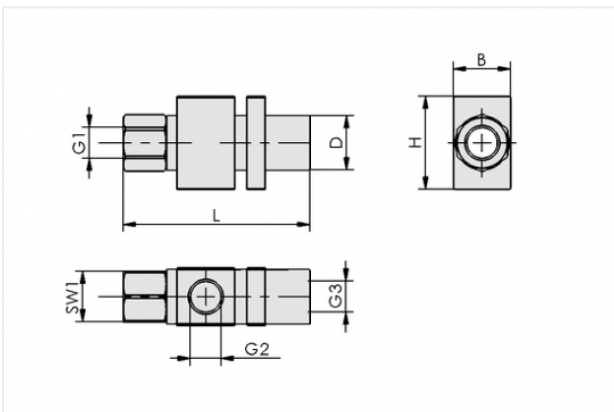

Attribute	Value
-----------	-------

B	26 mm
D	20 mm
G1	G1/4"-F
G2	G1/4"-F
G3	G3/8"-F
H	38 mm
L	90 mm
SW1	17 mm

Technical Data

Contact to Schmalz

J. Schmalz GmbH | Johannes-Schmalz-Straße, 72293 Glatten, Deutschland | +49 7443 2403-102 | customercenter@schmalz.de

Attribute	Value
Nozzle diameter	2 mm
Degree of evacuation	55 %
Suction rate (max)	170 l/min
Suction rate (max)	10.2 m ³ /h
Suction rate (max)	6.003 cfm
Air consumption (during evac.)	186 l/min
Air consumption (during evac.)	11.2 m ³ /h
Air consumption (during evac.)	6.568 cfm
Pressure range (operating pressure)	3.0 ... 6.0 bar
Pressure range (operating pressure)	43.5 ... 87.0 psi
Pressure optimal	5 bar
Pressure optimal	72.5 psi
Int. hose diameter (recom.) comp.-air	4 mm
Int. hose diameter (recom.) vacuum side	9 mm
Weight	118 g
Ambient temperature	-10 ... 80 °C

Note:

- Air consumption: At optimal operating pressure
- Hose diameter: For max. length 2 m