

Flexolink FLK G1/2-IG G1/2-AG V

Part no.: 10.01.03.00207

<https://www.schmalz.com/10.01.03.00207>



Homepage > Vacuum Technology for Automation > Vacuum Components > Mounting Elements > Jointed Mountings > Flexolink FLK > FLK G1/2-IG G1/2-AG V

Flexible suction cup mounting for adaptation to sloping surfaces



Thread G1: G1/2-F
Thread G2: G1/2-M
Shape: Reinforced
Ambient temperature: 0 ... 70 °C

Design Data

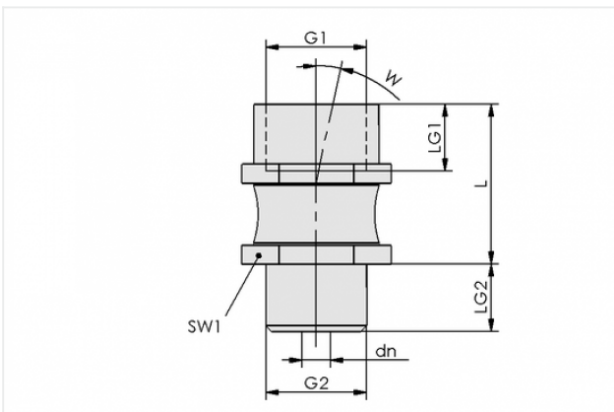

Attribute	Value
-----------	-------

dn	6 mm
G1	G1/2"-F
G2	G1/2"-M
L	53 mm
LG1	14 mm
LG2	14 mm
SW1	36 mm
W	8 °

Technical Data

Contact to Schmalz

J. Schmalz GmbH | Johannes-Schmalz-Straße, 72293 Glatten, Deutschland | +49 7443 2403-102 | customercenter@schmalz.de



Attribute	Value
Bending moment	65 Nm
Vertical load	4500 N
Weight	190 g