

# Flexolink FLK G1/2-AG G1/2-AG

Part no.: 10.01.03.00153

<https://www.schmalz.com/10.01.03.00153>



Homepage > Vacuum Technology for Automation > Vacuum Components > Mounting Elements > Jointed Mountings > Flexolink FLK > FLK G1/2-AG G1/2-AG

## Flexible suction cup mounting for adaptation to sloping surfaces



Thread G1: G1/2-M  
Thread G2: G1/2-M  
Ambient temperature: 0 ... 70 °C

### Design Data

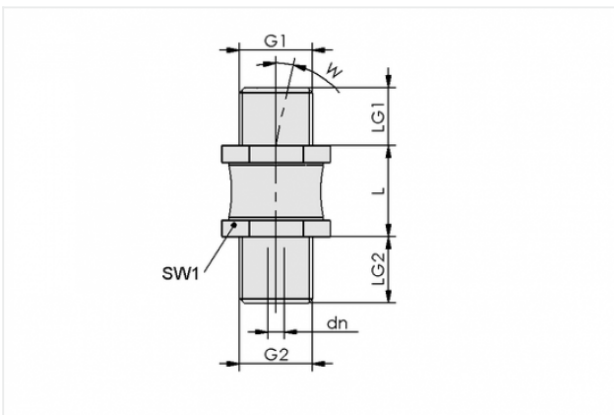

Attribute	Value
-----------	-------

dn	5.5 mm
G1	G1/2"-M
G2	G1/2"-M
L	21 mm
LG1	14 mm
LG2	14 mm
SW1	27 mm
W	12 °

### Technical Data

#### Contact to Schmalz

J. Schmalz GmbH | Johannes-Schmalz-Straße, 72293 Glatten, Deutschland | +49 7443 2403-102 | [customercenter@schmalz.de](mailto:customercenter@schmalz.de)

Attribute	Value
Bending moment	65 Nm
Vertical load	3000 N
Weight	100 g

---

---