

## Flexible suction cup mounting for adaptation to sloping surfaces

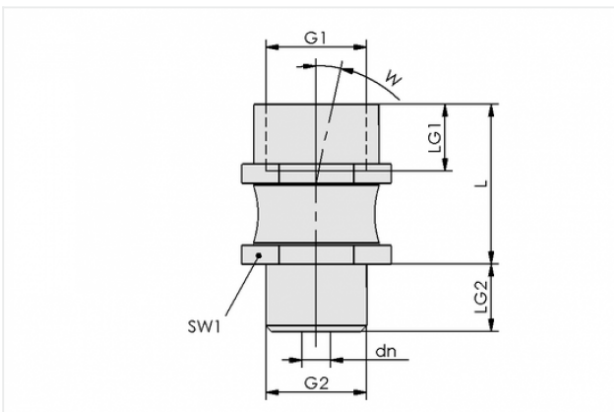

Thread G1: G1/2-F  
Thread G2: G1/2-M  
Ambient temperature: 0 ... 70 °C

### Design Data



Attribute	Value
dn	6 mm
G1	G1/2"-F
G2	G1/2"-M
L	33.5 mm
LG1	14 mm
LG2	14 mm
SW1	27 mm
W	12 °

### Technical Data

#### Contact to Schmalz

Attribute	Value
Bending moment	50 Nm
Vertical load	3000 N
Weight	100 g

---

---