

Feed ejector SEC-400

Part no.: 10.02.01.00080

<https://www.schmalz.com/10.02.01.00080>



Homepage > Vacuum Technology for Automation > Vacuum Components > Special Grippers > Feed Ejectors > Feed Ejectors SEC > SEC-400

Powerful ejector for very porous parts



Nozzle size: 40 mm

Suction rate (max): 135 m³/h

Design Data

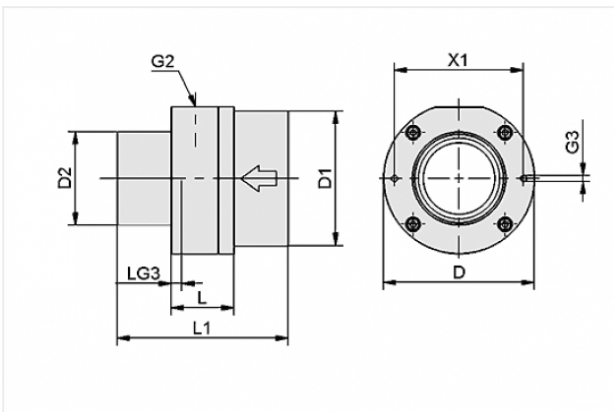

Attribute	Value
-----------	-------

D	84 mm
---	-------

D1	75 mm
----	-------

D2	52 mm
----	-------

G2	G3/8"-F
----	---------

G3	M4-F
----	------

L	35 mm
---	-------

L1	95 mm
----	-------

LG3	14 mm
-----	-------

X1	72 mm
----	-------

Technical Data

Contact to Schmalz

J. Schmalz GmbH | Johannes-Schmalz-Straße, 72293 Glatten, Deutschland | +49 7443 2403-102 | customercenter@schmalz.de

Attribute	Value
Nozzle diameter	40 mm
Vacuum (max)	-35 mbar
Suction rate (max)	2250 l/min
Suction rate (max)	135 m ³ /h
Air consumption (during evac.)	445 l/min
Air consumption (during evac.)	26.7 m ³ /h
Pressure range (operating pressure)	2.0 ... 6.0 bar
Ambient temperature	-20 ... 80 °C
Weight	0.525 kg
Vacuum (max)	-1.033 inHg
Suction rate (max)	79.456 cfm
Air consumption (during evac.)	15.714 cfm
Pressure range (operating pressure)	29.0 ... 87.0 psi

Note:

- Air consumption: At optimal operating pressure (4,5 bar)