

Suction plate (round)

SPL-HT 120 FPM-F-65

<https://www.schmalz.com/10.01.01.13435>



Part no.: 10.01.01.13435

Homepage > Vacuum Technology for Automation > Vacuum Components > Vacuum Suction Cups > Suction Cups for High-Temperature

Applications > SPL-HT 120 FPM-F-65

Suction plate for high-temperature applications



Size: 120
Suction cup material:
Fluorocautchuc FPM-F
Material hardness: 65 °Sh
Workpiece temperature max.: 400 °C

Design Data

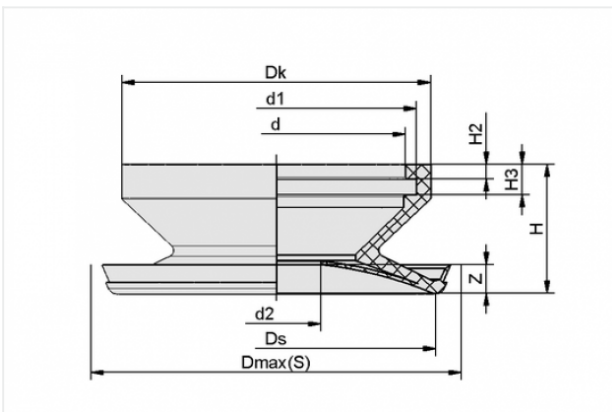

Attribute	Value
-----------	-------

d	88 mm
---	-------

d1	96 mm
----	-------

d2	15 mm
----	-------

Dk	105 mm
----	--------

Dmax(S)	130 mm
---------	--------

Ds	120 mm
----	--------

H	43 mm
---	-------

H2	5 mm
----	------

H3	10 mm
----	-------

Z	25 mm
---	-------

Contact to Schmalz

J. Schmalz GmbH | Johannes-Schmalz-Straße, 72293 Glatten, Deutschland | +49 7443 2403-102 | customercenter@schmalz.de

Technical Data

Attribute	Value
Suction force	675 N
Volume	255 cm ³
Curve radius (min) (convex)	300 mm
Size	120
Workpiece temperature max.	400 °C
Suction cup material	Fluorocaoutchuc FPM-F
Weight	138.1 g
