

Bell suction cup (oval)

<https://www.schmalz.com/10.01.01.11656>



SAOG 95x40 NBR-45
M14x1.5-AG

Part no.: 10.01.01.11656

Homepage > Vacuum Technology for Automation > Vacuum Components > Vacuum Suction Cups > Suction Cups for Handling Sheet Metal > Bell-Shaped Suction Cups SAOG (Oval) > SAOG 95x40 NBR-45 M14x1.5-AG

Bell suction cup (oval) for very dynamic handling of smooth and oily workpieces



Dimensions (LxB): 95 x 40 mm

Suction cup material:

Nitrile rubber NBR

Material hardness: 45 °Sh

Nipple material: Aluminium

Vacuum connection: M14x1.5-M

Design Data

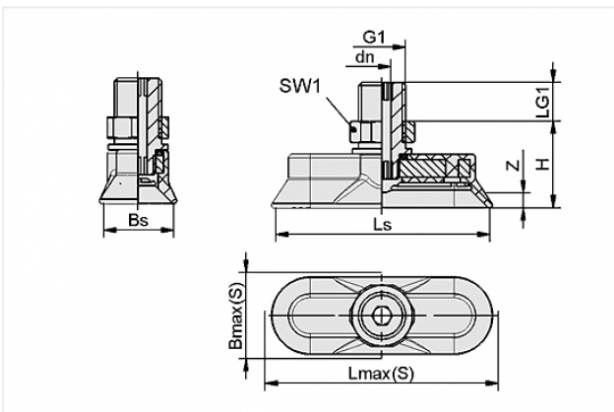

Attribute	Value
-----------	-------

Bmax(S)	46 mm
---------	-------

Bs	40 mm
----	-------

dn	5.2 mm
----	--------

G1	M14x1.5-M
----	-----------

H	29.5 mm
---	---------

LG1	10 mm
-----	-------

Lmax(S)	102 mm
---------	--------

Ls	95 mm
----	-------

SW1	22 mm
-----	-------

Z	6 mm
---	------

Contact to Schmalz

J. Schmalz GmbH | Johannes-Schmalz-Straße, 72293 Glatten, Deutschland | +49 7443 2403-102 | customercenter@schmalz.de

Technical Data

Attribute	Value
Suction force	165 N
Lateral force	97 N
Lateral force (oily surface)	68 N
Volume	26.9 cm ³
Curve radius (min) (convex)	25 mm
Internal hose diameter (recom.)	4 mm
Dimensions (LxB)	95 x 40 mm
Suction cup material	Nitrile rubber NBR
Weight	61.5 g
Number of folds	0

Note:

- Suction force: The specified suction forces are theoretical values at a vacuum of -0.6 bar and with a smooth, dry workpiece surface - they do not include a safety factor
- Lateral force: The specified lateral forces are values measured at a vacuum of -0.6 bar with a dry or oily, smooth, flat workpiece surface. Depending on the workpiece surface and its quality, the actual values may deviate from these values
- Hose diameter: The recommended hose diameter refers to a hose length of approx. 2 m