

# Bell suction cup (oval)

## SAOG 60x20 NBR-45 G3/8-AG

<https://www.schmalz.com/10.01.01.11758>



Part no.: 10.01.01.11758

Homepage > Vacuum Technology for Automation > Vacuum Components > Vacuum Suction Cups > Suction Cups for Handling Sheet Metal > Bell-Shaped Suction Cups SAOG (Oval) > SAOG 60x20 NBR-45 G3/8-AG

## Bell suction cup (oval) for very dynamic handling of smooth and oily workpieces



Dimensions (LxB): 60 x 20 mm

Suction cup material:

Nitrile rubber NBR

Material hardness: 45 °Sh

Nipple material: Aluminium

Vacuum connection: G3/8-M

### Design Data

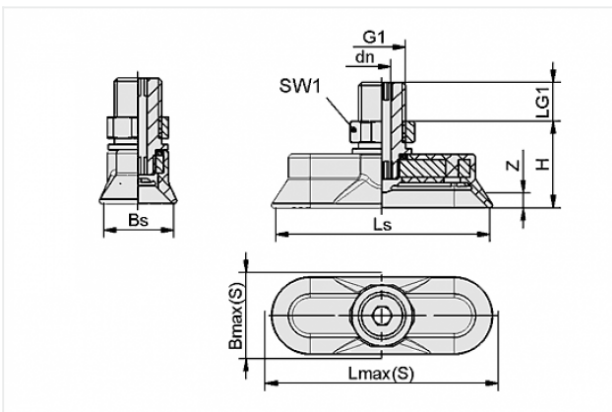

Attribute	Value
Bmax(S)	26 mm
Bs	20 mm
dn	5 mm
G1	G3/8"-M
H	21 mm
LG1	8 mm
Lmax(S)	66 mm
Ls	60 mm
SW1	22 mm
Z	4.5 mm

### Contact to Schmalz

J. Schmalz GmbH | Johannes-Schmalz-Straße, 72293 Glatten, Deutschland | +49 7443 2403-102 | [customercenter@schmalz.de](mailto:customercenter@schmalz.de)

## Technical Data

Attribute	Value
Suction force	56 N
Lateral force	35 N
Lateral force (oily surface)	10 N
Volume	4.86 cm <sup>3</sup>
Curve radius (min) (convex)	12.5 mm
Internal hose diameter (recom.)	4 mm
Dimensions (LxB)	60 x 20 mm
Suction cup material	Nitrile rubber NBR
Weight	29.9 g
Number of folds	0

### Note:

- Suction force: The specified suction forces are theoretical values at a vacuum of -0.6 bar and with a smooth, dry workpiece surface - they do not include a safety factor
- Lateral force: The specified lateral forces are values measured at a vacuum of -0.6 bar with a dry or oily, smooth, flat workpiece surface. Depending on the workpiece surface and its quality, the actual values may deviate from these values
- Hose diameter: The recommended hose diameter refers to a hose length of approx. 2 m