

# Bellows suction cup HT2 (round)

<https://www.schmalz.com/10.01.06.03318>



## SAB 80 HT2-65 G3/8-IG

Part no.: 10.01.06.03318

Homepage > Vacuum Technology for Automation > Vacuum Components > Vacuum Suction Cups > Suction Cups for Handling Sheet Metal >

Bellows Suction Cups SAB HT2 (1.5 Folds) > SAB 80 HT2-65 G3/8-IG

## Bellows suction cup (round) for handling hot workpieces



Size: 80

Suction cup material:

High temp material HT2

Material hardness: 65 °Sh

Temperature resistance: 250 °C

Vacuum connection: G3/8-F

Number of folds: 1.5

Nipple material: Aluminium

## Design Data

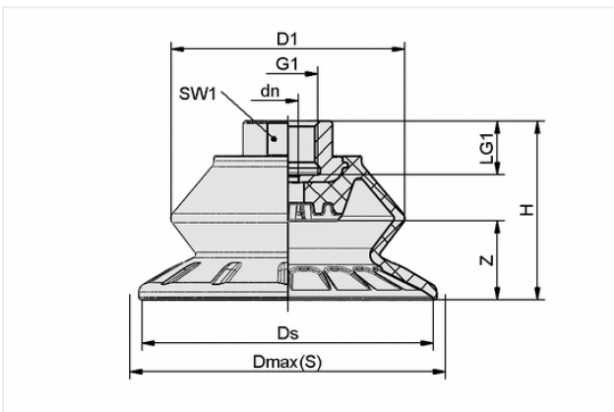

Attribute	Value
-----------	-------

dn	6 mm
----	------

D1	65 mm
----	-------

Dmax(S)	88 mm
---------	-------

Ds	81.2 mm
----	---------

G1	G3/8"-F
----	---------

H	49.8 mm
---	---------

LG1	15 mm
-----	-------

SW1	22 mm
-----	-------

Z	22 mm
---	-------

## Contact to Schmalz

J. Schmalz GmbH | Johannes-Schmalz-Straße, 72293 Glatten, Deutschland | +49 7443 2403-102 | [customercenter@schmalz.de](mailto:customercenter@schmalz.de)

## Technical Data

Attribute	Value
Suction force	135 N
Pull-off force	221 N
Lateral force	217 N
Volume	75.4 cm <sup>3</sup>
Curve radius (min) (convex)	40 mm
Internal hose diameter (recom.)	6 mm
Size	80
Connection	G3/8"-F
Suction cup material	High temp material HT2
Material hardness	65 °Sh
Weight	85.5 g
Number of folds	1.5
Product family	SAB