

Bellows suction cup HT2 (round)

<https://www.schmalz.com/10.01.06.03451>



SAB 50 HT2-65 G1/4-IG

Part no.: 10.01.06.03451

Homepage > Vacuum Technology for Automation > Vacuum Components > Vacuum Suction Cups > Suction Cups for Handling Sheet Metal >

Bellows Suction Cups SAB HT2 (1.5 Folds) > SAB 50 HT2-65 G1/4-IG

Bellows suction cup (round) for handling hot workpieces



Size: 50
Suction cup material:
High temp material HT2
Material hardness: 65 °Sh
Temperature resistance: 250 °C
Vacuum connection: G1/4-F
Number of folds: 1.5
Nipple material: Aluminium

Design Data

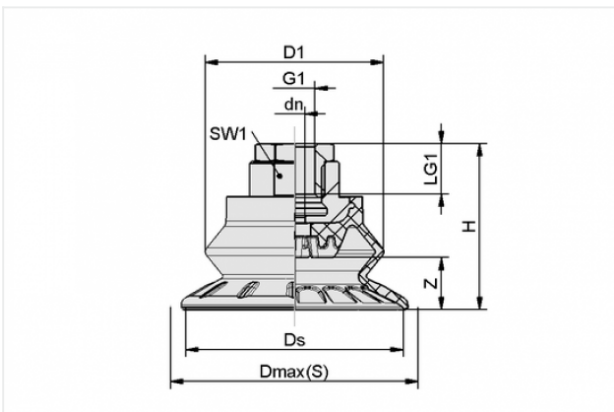

Attribute	Value
-----------	-------

dn	6 mm
D1	42.1 mm
Dmax(S)	56 mm
Ds	50.2 mm
G1	G1/4"-F
H	41.9 mm
LG1	20 mm
SW1	22 mm
Z	11.5 mm

Contact to Schmalz

J. Schmalz GmbH | Johannes-Schmalz-Straße, 72293 Glatten, Deutschland | +49 7443 2403-102 | customercenter@schmalz.de

Technical Data

Attribute	Value
Suction force	53 N
Pull-off force	91 N
Lateral force	102 N
Volume	18.9 cm ³
Curve radius (min) (convex)	25 mm
Internal hose diameter (recom.)	6 mm
Size	50
Connection	G1/4"-F
Suction cup material	High temp material HT2
Material hardness	65 °Sh
Weight	52.1 g
Number of folds	1.5
Product family	SAB