

# Bell suction cup (round)

<https://www.schmalz.com/10.01.19.00043>



## SAXM 100 ED-85 RA

Part no.: 10.01.19.00043

Homepage > Vacuum Technology for Automation > Vacuum Components > Vacuum Suction Cups > Suction Cups for Handling Sheet Metal > Bell-Shaped Suction Cups SAXM > SAXM 100 ED-85 RA

### Bell suction cup (round) for best adaptation to strongly curved surfaces



Size: 100  
Suction cup material: Elastodur  
Material hardness: 85 °Sh  
Vacuum connection:  
Rectangular adapter  
Nipple material: Aluminium

#### Design Data

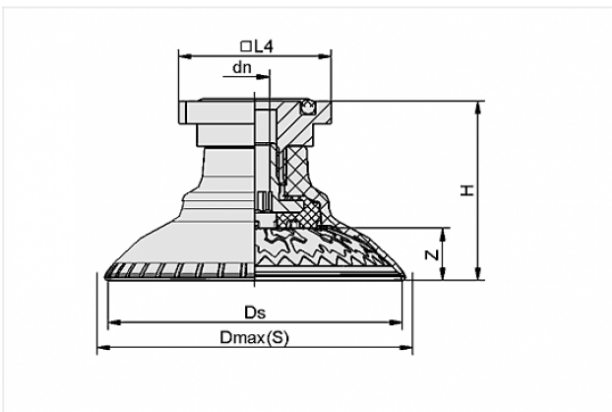

Attribute	Value
-----------	-------

dn	6.1 mm
Dmax(S)	111.1 mm
Ds	99.7 mm
H	48.7 mm
L4	31.8 mm
Z	17.1 mm

#### Technical Data

Attribute	Value
Suction force	412 N
Lateral force	230 N

#### Contact to Schmalz

J. Schmalz GmbH | Johannes-Schmalz-Straße, 72293 Glatten, Deutschland | +49 7443 2403-102 | [customercenter@schmalz.de](mailto:customercenter@schmalz.de)

Attribute	Value
Lateral force (oily surface)	414 N
Volume	95.5 cm <sup>3</sup>
Curve radius (min) (convex)	40 mm
Internal hose diameter (recom.)	6 mm
Size	100
Connection	Rectangular adapter
Number of folds	0
Suction cup material	Elastodur
Material hardness	85 °Sh
Weight	72.8 g
Product family	SAXM

**Note:**

- Suction force: The specified suction forces are theoretical values at a vacuum of -0.6 bar and with a smooth, dry workpiece surface - they do not include a safety factor
- Lateral force: The specified lateral forces are values measured at a vacuum of -0.6 bar with a dry or oily, smooth, flat workpiece surface. Depending on the workpiece surface and its quality, the actual values may deviate from these values
- Hose diameter: The recommended hose diameter refers to a hose length of approx. 2 m

**Spare Parts**



**SC-A 065 RA L**

Part no. 10.01.06.02817

Schmalz-Connector upper part

Connection geometry: 065

Vacuum connection:

Rectangular adapter

Fitting length: 9.5 mm

Construction: Self Locking



**SAXM 100 ED-85 SC065**

Part no. 10.01.19.00009

High-Speed bell shaped suction cup (round) very dynamic handling of smooth and oily workpieces

Size: 100

Suction cup material: Elastodur

Material hardness: 85 °Sh



**SC-S 065 FDC-L**

Part no. 10.01.06.02805

Schmalz-Connector lower part

Size: 065

Construction:

Frict elem with Self lock