

# Bell suction cup (round)

<https://www.schmalz.com/10.01.19.00101>



## SAXM 20 ED-85 G1/4-AG

Part no.: 10.01.19.00101

Homepage > Vacuum Technology for Automation > Vacuum Components > Vacuum Suction Cups > Suction Cups for Handling Sheet Metal > Bell-Shaped Suction Cups SAXM > SAXM 20 ED-85 G1/4-AG

### Bell suction cup (round) for best adaptation to strongly curved surfaces



Size: 20  
Suction cup material: Elastodur  
Material hardness: 85 °Sh  
Vacuum connection: G1/4-M  
Nipple material: Aluminium

### Design Data

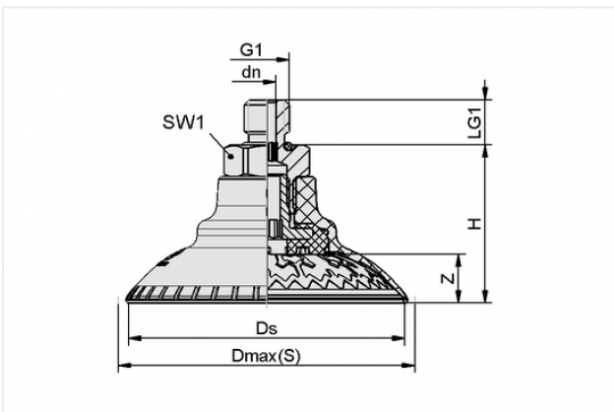

Attribute	Value
-----------	-------

dn	5.1 mm
----	--------

Dmax(S)	26 mm
---------	-------

Ds	21.8 mm
----	---------

G1	G1/4"-M
----	---------

H	23.7 mm
---	---------

LG1	10 mm
-----	-------

SW1	17 mm
-----	-------

Z	3 mm
---	------

### Technical Data

#### Contact to Schmalz

J. Schmalz GmbH | Johannes-Schmalz-Straße, 72293 Glatten, Deutschland | +49 7443 2403-102 | [customercenter@schmalz.de](mailto:customercenter@schmalz.de)

Attribute	Value
Suction force	20 N
Lateral force	15 N
Lateral force (oily surface)	20 N
Volume	1.55 cm <sup>3</sup>
Curve radius (min) (convex)	20 mm
Internal hose diameter (recom.)	5 mm
Size	20
Connection	G1/4"-M
Number of folds	0
Suction cup material	Elastodur
Material hardness	85 °Sh
Weight	14.5 g
Product family	SAXM

**Note:**

- Suction force: The specified suction forces are theoretical values at a vacuum of -0.6 bar and with a smooth, dry workpiece surface - they do not include a safety factor
- Lateral force: The specified lateral forces are values measured at a vacuum of -0.6 bar with a dry or oily, smooth, flat workpiece surface. Depending on the workpiece surface and its quality, the actual values may deviate from these values
- Hose diameter: The recommended hose diameter refers to a hose length of approx. 2 m

**Spare Parts**



**SC-A 045 G1/4-AG L**

Part no. 10.01.06.02818

Schmalz-Connector upper part

Connection geometry: 045

Thread G1: G1/4-M

Fitting length: 7.2 mm

Construction: Self Locking



**SAXM 20 ED-85 SC045**

Part no. 10.01.19.00003

High-Speed bell shaped suction cup (round) very dynamic handling of smooth and oily workpieces

Size: 20

Suction cup material: Elastodur

Material hardness: 85 °Sh



**SC-S 045 FDC-L**

Part no. 10.01.06.02803

Schmalz-Connector lower part

Size: 045

Construction:

Frict elem with Self lock