

# Bell suction cup (round)

<https://www.schmalz.com/10.01.19.00232>



## SAX 60 ED-85 M16-AG

Part no.: 10.01.19.00232

Homepage > Vacuum Technology for Automation > Vacuum Components > Vacuum Suction Cups > Suction Cups for Handling Sheet Metal > Bell-Shaped Suction Cups SAX > SAX 60 ED-85 M16-AG

### Bell suction cup (round) for best adaptation to strongly curved surfaces



Size: 60  
Suction cup material: Elastodur  
Material hardness: 85 °Sh  
Vacuum connection: M16-M  
Nipple material: Aluminium

### Design Data

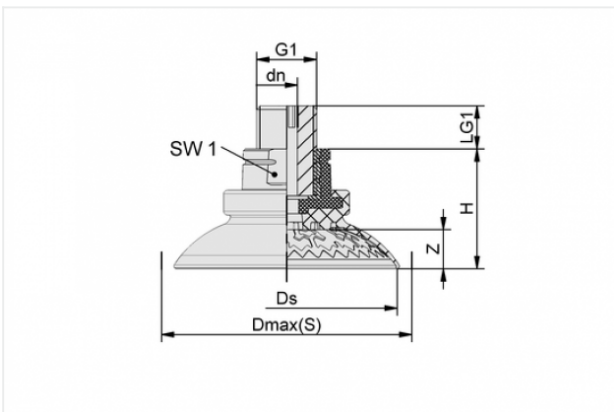

Attribute	Value
-----------	-------

dn	6.1 mm
Dmax(S)	69.7 mm
Ds	61.5 mm
G1	M16-M
H	33.4 mm
LG1	12 mm
SW1	22 mm
Z	10.9 mm

### Technical Data

#### Contact to Schmalz

J. Schmalz GmbH | Johannes-Schmalz-Straße, 72293 Glatten, Deutschland | +49 7443 2403-102 | [customercenter@schmalz.de](mailto:customercenter@schmalz.de)

Attribute	Value
Suction force	154 N
Lateral force	107 N
Lateral force (oily surface)	155 N
Volume	25 cm <sup>3</sup>
Curve radius (min) (convex)	30 mm
Size	60
Connection	M16-M
Number of folds	0
Suction cup material	Elastodur
Material hardness	85 °Sh
Weight	41 g
Product family	SAX

**\*The specified suction forces are theoretical values at a vacuum of -0.6 bar and with a smooth, dry workpiece surface - they do not include a safety factor.**

**\*\*The specified lateral forces are values measured at a vacuum of -0.6 bar with a dry or oily, smooth, flat workpiece surface. Depending on the workpiece surface and its quality, the actual values may deviate from these values.**

**\*\*\*The recommended hose diameter refers to a hose length of approx. 2 m.**