

Bell suction cup (round)

<https://www.schmalz.com/10.01.19.00152>



SAX 60 ED-85 G3/8-IG

Part no.: 10.01.19.00152

Homepage > Vacuum Technology for Automation > Vacuum Components > Vacuum Suction Cups > Suction Cups for Handling Sheet Metal > Bell-Shaped Suction Cups SAX > SAX 60 ED-85 G3/8-IG

Bell suction cup (round) for best adaptation to strongly curved surfaces



Size: 60
Suction cup material: Elastodur
Material hardness: 85 °Sh
Vacuum connection: G3/8"-F
Nipple material: TPU-GF

Design Data

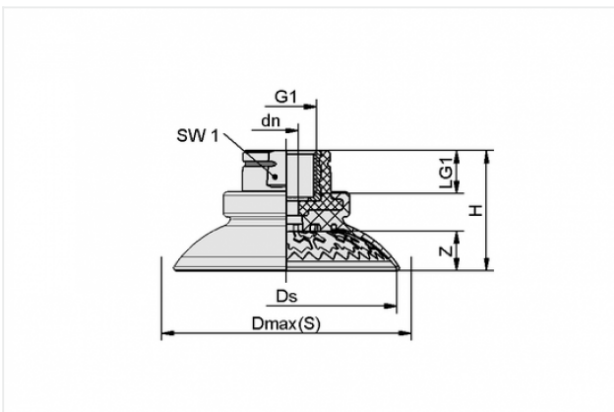

Attribute	Value
-----------	-------

dn	6.75 mm
----	---------

Dmax(S)	69.7 mm
---------	---------

Ds	61.5 mm
----	---------

G1	G3/8"-F
----	---------

H	33.4 mm
---	---------

LG1	12 mm
-----	-------

SW1	22 mm
-----	-------

Z	10.9 mm
---	---------

Technical Data

Contact to Schmalz

J. Schmalz GmbH | Johannes-Schmalz-Straße, 72293 Glatten, Deutschland | +49 7443 2403-102 | customercenter@schmalz.de

Attribute	Value
Suction force	154 N
Lateral force	107 N
Lateral force (oily surface)	155 N
Volume	25.2 cm ³
Curve radius (min) (convex)	30 mm
Size	60
Connection	G3/8"-F
Number of folds	0
Suction cup material	Elastodur
Material hardness	85 °Sh
Weight	29.5 g
Product family	SAX

***The specified suction forces are theoretical values at a vacuum of -0.6 bar and with a smooth, dry workpiece surface - they do not include a safety factor.**

****The specified lateral forces are values measured at a vacuum of -0.6 bar with a dry or oily, smooth, flat workpiece surface. Depending on the workpiece surface and its quality, the actual values may deviate from these values.**

*****The recommended hose diameter refers to a hose length of approx. 2 m.**