

Suction plate (oval)

SPLO 300x100 NBR-55 TV

<https://www.schmalz.com/10.01.05.00188>



Part no.: 10.01.05.00188

Homepage > Vacuum Technology for Automation > Vacuum Components > Vacuum Suction Cups > Flat Suction Cups (Oval) > Suction Plates

SPLO > SPLO 300x100 NBR-55 TV

Flat suction cup (oval) for narrow or curved workpieces



Dimensions (LxB): 300 x 100 mm

Suction cup material:

Nitrile rubber NBR

Material hardness: 55 °Sh

Additional feature: Sensing valve

Suction cup area: 208.3 cm²

Design Data

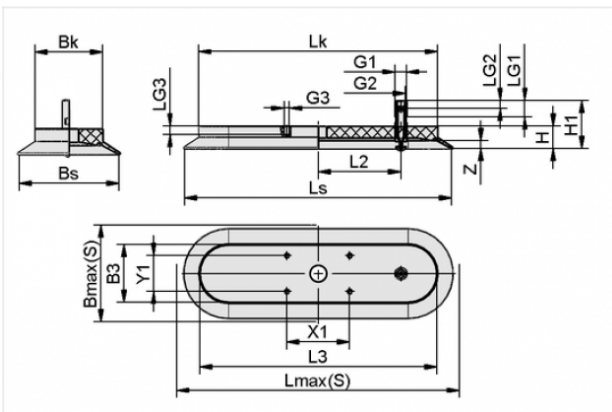

Attribute	Value
B3	65 mm
Bk	67.7 mm
Bmax(S)	108 mm
Bs	98.8 mm
G1	G1/4"-M
G2	G1/8"-F
G3	M6-F
H	25 mm
H1	53.5 mm
L2	92 mm
L3	264 mm
LG1	13 mm
LG2	9.5 mm

Contact to Schmalz

J. Schmalz GmbH | Johannes-Schmalz-Straße, 72293 Glatten, Deutschland | +49 7443 2403-102 | customercenter@schmalz.de

Attribute	Value
LG3	9 mm
Lk	266.7 mm
Lmax(S)	308 mm
Ls	297.8 mm
X1	70 mm
Y1	40 mm
Z	8.8 mm

Technical Data

Attribute	Value
Suction force	1250 N
Volume	256.392 cm ³
Curve radius (min) (convex)	175 mm
Number of folds	0
Dimensions (LxB)	300 x 100 mm
Suction cup material	Nitrile rubber NBR
Weight	1300 g
Product family	SPLO

Note:

- Suction force: The specified suction forces are theoretical values at a vacuum of -0.6 bar and with a smooth, dry workpiece surface - they do not include a safety factor
-
-