

Suction plate (oval)

SPLO 250x55 NBR-55

Part no.: 10.01.05.00186

<https://www.schmalz.com/10.01.05.00186>



Homepage > Vacuum Technology for Automation > Vacuum Components > Vacuum Suction Cups > Flat Suction Cups (Oval) > Suction Plates

SPLO > SPLO 250x55 NBR-55

Flat suction cup (oval) for narrow or curved workpieces

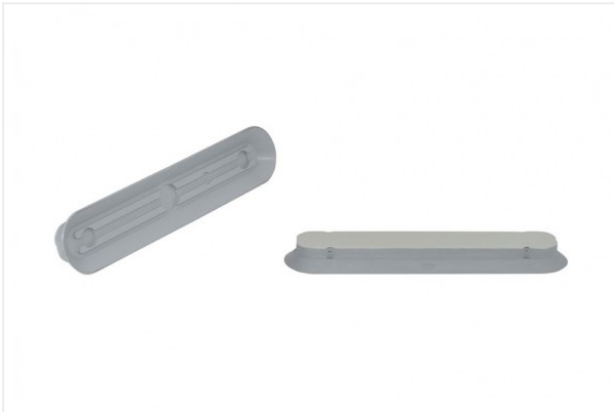

Dimensions (LxB): 250 x 55 mm

Suction cup material:

Nitrile rubber NBR

Material hardness: 55 °Sh

Design Data

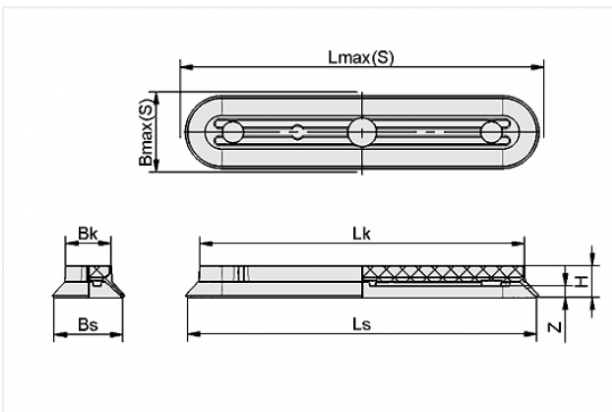

Attribute	Value
-----------	-------

B3	29 mm
----	-------

Bk	31.5 mm
----	---------

Bmax(S)	58 mm
---------	-------

Bs	47.6 mm
----	---------

H	22 mm
---	-------

L3	224.5 mm
----	----------

Lk	226 mm
----	--------

Lmax(S)	255 mm
---------	--------

Ls	243 mm
----	--------

Z	8 mm
---	------

Contact to Schmalz

J. Schmalz GmbH | Johannes-Schmalz-Straße, 72293 Glatten, Deutschland | +49 7443 2403-102 | customercenter@schmalz.de

Technical Data

Attribute	Value
Suction force	590 N
Volume	82.774 cm ³
Curve radius (min) (convex)	50 mm
Number of folds	0
Dimensions (LxB)	250 x 55 mm
Suction cup material	Nitrile rubber NBR
Weight	425 g
Product family	SPLO

Note:

- Suction force: The specified suction forces are theoretical values at a vacuum of -0.6 bar and with a smooth, dry workpiece surface - they do not include a safety factor
-
-