

Suction plate (oval)

SPLO 150x55 NBR-55

Part no.: 10.01.05.00046

<https://www.schmalz.com/10.01.05.00046>



Homepage > Vacuum Technology for Automation > Vacuum Components > Vacuum Suction Cups > Flat Suction Cups (Oval) > Suction Plates

SPLO > SPLO 150x55 NBR-55

Flat suction cup (oval) for narrow or curved workpieces



Dimensions (LxB): 150 x 55 mm

Suction cup material:

Nitrile rubber NBR

Material hardness: 55 °Sh

Design Data

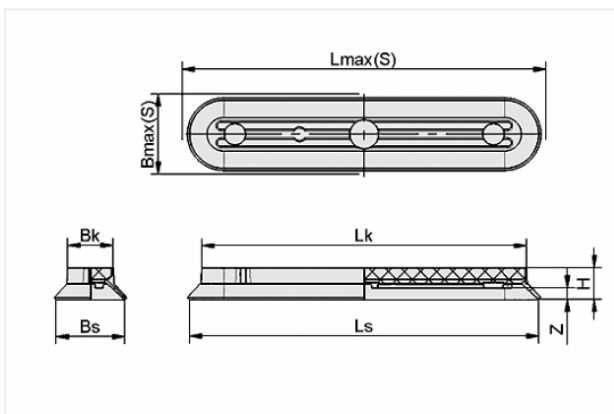

Attribute	Value
-----------	-------

B3	29 mm
----	-------

Bk	32 mm
----	-------

Bmax(S)	61 mm
---------	-------

Bs	52.3 mm
----	---------

H	19.4 mm
---	---------

L3	124 mm
----	--------

Lk	126.5 mm
----	----------

Lmax(S)	157 mm
---------	--------

Ls	147.3 mm
----	----------

Z	6.9 mm
---	--------

Contact to Schmalz

J. Schmalz GmbH | Johannes-Schmalz-Straße, 72293 Glatten, Deutschland | +49 7443 2403-102 | customercenter@schmalz.de

Technical Data

Attribute	Value
Suction force	340 N
Volume	60 cm ³
Curve radius (min) (convex)	75 mm
Number of folds	0
Dimensions (LxB)	150 x 55 mm
Suction cup material	Nitrile rubber NBR
Weight	215 g
Product family	SPLO

Note:

- Suction force: The specified suction forces are theoretical values at a vacuum of -0.6 bar and with a smooth, dry workpiece surface - they do not include a safety factor
-
-