

SOFT-CLOSE HINGE HG-JV65 For Vertical Use



Passed 50,000 open/close private cycle test



HG-JV65-S-BL



HG-JV65-S-LGR



Comes with screw covers

- Closing speed of doors is adjustable with a hex key.
- Comes with self-close function which can hold doors closed.

[Specification]

- Temperature: 0 - 40 °C

[Remarks]

- Please use with stoppers to prevent doors from opening over 180°.

[Parts Included]

- Screw cover

[Recommended Screw]

- For wood:
 - Binding head tapping screw M5
 - Pan head tapping screw M5
- For sheet metal:
 - Binding head screw M5
 - Pan head screw M5
 - Button bolt M5

Video Link



[Operating Range]

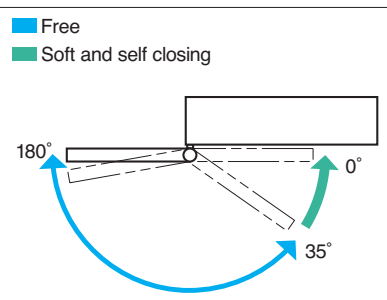

[Closing Speed Adjustment]

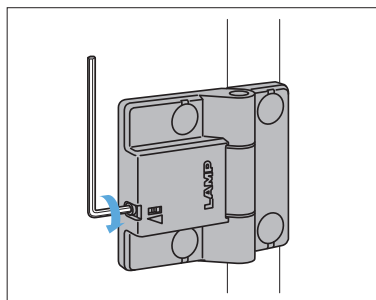

Closing speed of doors is adjustable with a hex key (size: 2.5).

[Installation]

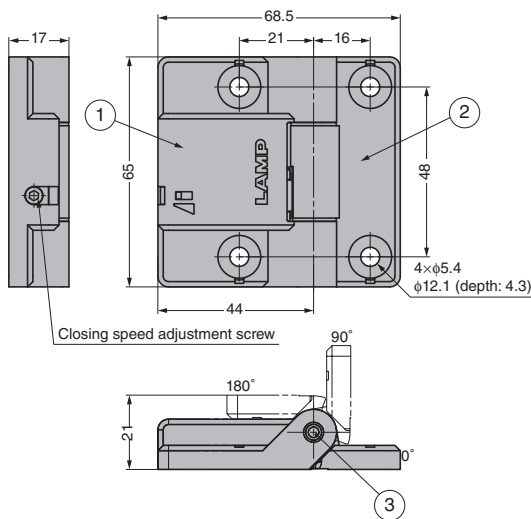
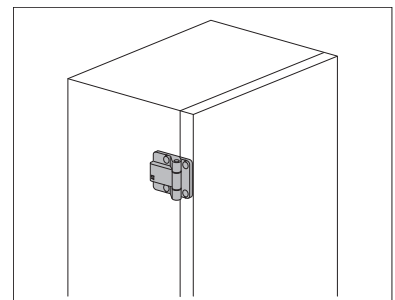

No.	Part Name	Material	Finish/Colour
①	Body A	Polyamide (PA)	Black, Light Grey
②	Body B	Steel	
③	Shaft	Brass	Nickel
-	Screw Cover	Elastomer (SPE)	Black, Light Grey

RoHS	CAD	Item Code	Item Name	Finish	Available Door Specs				Weight (g)	Box (pc)	Carton (pcs)
					Width (mm)	Height (mm)	Weight/2pc (kg)	Weight/3pc (kg)			
●	●	170-046-272	HG-JV65-S-BL	Black	Max. 700	Max. 2400	1.0 - 7.0	7.0 - 12.0	85	1	60
●	●	170-046-273	HG-JV65-S-LGR	Light Grey							