

## STAINLESS STEEL MINI SLIDE (2-WAY) SCR2

LOAD CAPACITY 137~177 N/pair

L=R

2-WAYS

SUS



- 3/4 extension (2 members).
- Only 15.5mm in height with small deflection, suitable for various places.

**[Remarks]**

- Types with slide length 80mm have no holes marked with ※.
- Install stopper separately to protect rails and retainers from strong shock.

**[Recommended Screws]**

- M2.6 low head screw (for outer member)
- M2.6 screw (for inner member) Screw length = Panel thickness + Max. 1.5 mm

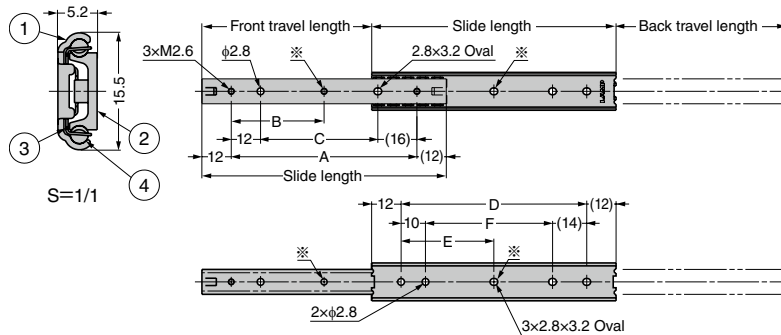

No.	Part Name	Material
①	Outer Member	Stainless Steel (SUS304)
②	Inner Member	
③	Retainer	Steel (SUJ)
④	Balls	

Sold by piece.

RoHS	CAD	Item Code	Item Name	Slide Length	Travel Length		A	B	C	D	E	F	Vertical Installation		Weight (g/pc)	Box (pcs)	Carton (pcs)
					Front	Back							Load Capacity N/pair	Load Capacity kgf/pair			
☑	☑	190-026-620	SCRW2-15-80A	80	48.5	48.5	56	-	28	56	-	32	137	14	21	200	400
☑	☑	190-026-621	SCRW2-15-100A	100	68.5	68.5	76	38	48	76	38	52	157	16	26	200	400
☑	☑	190-026-622	SCRW2-15-150A	150	94.5	94.5	126	63	98	126	63	102	177	18	41	100	200

## STAINLESS STEEL MINI SLIDE (2-WAY) SCR2-15S

LOAD CAPACITY 137~177 N/pair

L=R

2-WAYS

SUS



- 3/4 extension (2 members).
- Only 15.5mm in height with small deflection, suitable for various places.
- Grease (NSF H1 Registered Food Grade Lubricants) for food machinery is used.

**[Remarks]**

- Types with slide length 80mm have no holes marked with ※.
- Install stopper separately to protect rails and retainers from strong shock.

**[Recommended Screws]**

- M2.6 low head screw (for outer member)
- M2.6 screw (for inner member) Screw length = Panel thickness + Max. 1.5 mm

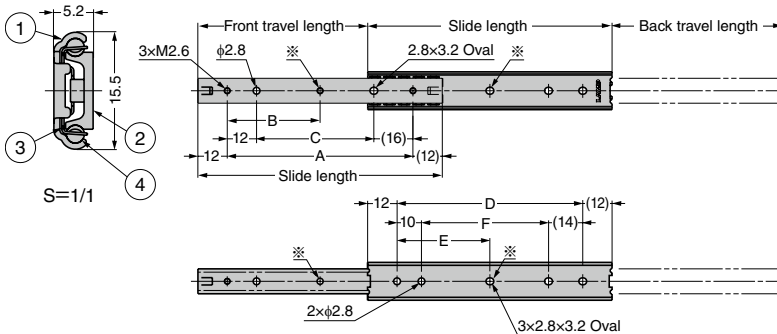

No.	Part Name	Material
①	Outer Member	Stainless Steel (SUS304)
②	Inner Member	
③	Retainer	Stainless Steel (SUS440)
④	Balls	

Sold by piece.

RoHS	CAD	Item Code	Item Name	Slide Length	Travel Length		A	B	C	D	E	F	Vertical Installation		Weight (g/pc)	Box (pcs)	Carton (pcs)
					Front	Back							Load Capacity N/pair	Load Capacity kgf/pair			
☑	☑	190-034-806	SCRW2-15S-80A	80	48.5	48.5	56	-	28	56	-	32	137	14	21	-	-
☑	☑	190-034-807	SCRW2-15S-100A	100	68.5	68.5	76	38	48	76	38	52	157	16	26	-	-
☑	☑	190-034-808	SCRW2-15S-150A	150	94.5	94.5	126	63	98	126	63	102	177	18	41	-	-

STAINLESS STEEL

ALUMINIUM

STEEL