

技術資料 Technische Documentatie **Documentation**
Documentação técnica Documentación técnica **Documentazione tecnica**
Technische Dokumentation Technical Documentation **Техническая документация**
Documentazione tecnica Technische documentatie
Техническая документация **Teknik Doküman** 技术资料
Documentazione tecnica Dokumentacja techniczna
Technische documentatie Documentación técnica **기술 자료** 技術資料
Documentation technique Teknik Doküman Dokumentacja techniczna
Technical Documentation **Documentazione tecnica** Technical Documentation
Dokumentacja techniczna 技术资料 Documentation technique
Техническая документация Technische Dokumentation **Teknik Doküman**
Dokumentacja techniczna **Technische documentatie**
Documentation technique **기술 자료** Dokumentacja techniczna



Kompaktejektor SCPb FS RP

Operating Instructions

Note

The operating instructions were originally written in German and have been translated into English. Store in a safe place for future reference. Subject to technical changes without notice. No responsibility is taken for printing or other types of errors.

Published by

© J. Schmalz GmbH, 12/18

This document is protected by copyright. J. Schmalz GmbH retains the rights established thereby. Reproduction of the contents, in full or in part, is only permitted within the limits of the legal provisions of copyright law. Any modifications to or abridgments of the document are prohibited without explicit written agreement from J. Schmalz GmbH.

Contact

J. Schmalz GmbH

Johannes-Schmalz-Str. 1

72293 Glatten, Germany

T: +49 7443 2403-0

schmalz@schmalz.de

www.schmalz.com

Contact information for Schmalz companies and trade partners worldwide can be found at:

www.schmalz.com/salesnetwork

Contents

1 Important information	5
1.1 Note on using these operating instructions	5
1.2 The technical documentation is part of the product	5
1.3 Warnings in this document.....	5
1.4 Symbol.....	5
2 Fundamental Safety Instructions	6
2.1 Standards of Technology	6
2.2 Emissions	6
2.3 Intended Use.....	6
2.4 Non-Intended Use	6
2.5 Personnel Qualification.....	7
2.6 Modifications to the Ejector	7
3 Product description	8
3.1 Description of the Ejector	8
3.1.1 Suction of the Workpiece (Vacuum Generation)	8
3.1.2 Depositing the Workpiece (Blowing Off)	8
3.1.3 Pneumatic Air Saving Function.....	8
3.2 Ejector Designation	9
3.3 Ejector Structure.....	10
4 Technical Data	11
4.1 General Parameters.....	11
4.2 Mechanical Data.....	11
4.2.1 Performance Data.....	11
4.2.2 Factory Settings	11
4.2.3 Dimensions.....	12
4.2.4 Pneumatic Circuit Plan	13
5 Transport and storage	14
5.1 Checking the Delivery	14
6 Installation	15

6.1	Installation Instructions.....	15
6.2	Installation	15
6.3	Pneumatic Connection	16
6.3.1	Connecting the Compressed Air and Vacuum	16
6.3.2	Instructions for the Pneumatic Connection	17
7	Operation	18
7.1	General Preparations	18
8	Help with Malfunctions.....	19
9	Maintenance.....	20
9.1	Safety	20
9.2	Cleaning the Ejector.....	20
10	Warranty.....	21
11	Spare and Wearing Parts.....	22
12	Decommissioning and recycling	23
12.1	Disposing of the Ejector.....	23
12.2	Materials Used	23
13	Appendix	24
13.1	SCPb_CEE_30.30.01.01874_00_DE-EN-FR-ES-IT-NL.pdf	25

1 Important information

1.1 Note on using these operating instructions

The J. Schmalz GmbH is generally referred to as Schmalz in these operating instructions.

These operating instructions contain important notes and information about the different operating phases of the product:

- Transport, storage, start of operations and decommissioning
- Safe operation, required maintenance, rectification of any faults

The operating instructions describe the product at the time of delivery by Schmalz.

1.2 The technical documentation is part of the product

1. For problem-free and safe operation, follow the instructions in the documents.
2. Keep the technical documentation in close proximity to the product. The documentation must be accessible to personnel at all times.
3. Pass on the technical documentation to subsequent users.
 - ⇒ Schmalz is not liable for damage or malfunctions that result from failure to heed these instructions.

If you still have questions after reading the technical documentation, contact the Customer Service Center on:

www.schmalz.com/services

1.3 Warnings in this document

Warnings warn against hazards that may occur when handling the product. This document contains three levels of danger that you can recognize by the signal word.

Signal word	Meaning
WARNING	Indicates a medium-risk hazard which, if not avoided, could result in death or serious injury.
CAUTION	Indicates a low-risk hazard which, if not avoided, could result in minor or moderate injury.
NOTE	Indicates a danger that leads to property damage.

1.4 Symbol



This sign indicates useful and important information.

- ✓ This symbol represents a prerequisite that must be met before installation and maintenance work.
- ▶ This sign represents an action to be performed.
- ⇒ This sign represents the result of an action.

Actions that consist of more than one step are numbered:

1. First action to be performed.
2. Second action to be performed.

2 Fundamental Safety Instructions

2.1 Standards of Technology

The ejector is built in accordance with the latest standards of technology and is shipped safely, however, hazards can arise during use.



⚠ WARNING

Failure to follow the instructions in this manual can lead to life-threatening injuries!

- ▶ Read the operating instructions carefully and observe the contents.
-

2.2 Emissions

The ejector emits noise due to the operation of compressed air.



⚠ WARNING

Noise pollution due to the escape of compressed air

Hearing damage!

- ▶ Wear ear protectors.
 - ▶ The ejector must only be operated with a silencer.
-

2.3 Intended Use

The ejector is designed to generate a vacuum for gripping and transporting objects when used in conjunction with suction cups. Operation is via a controller using external solenoid valves.

Neutral gases are approved as evacuation media. Neutral gases include air, nitrogen and inert gases (e.g. argon, xenon and neon).

The product is intended for industrial use.

Intended use includes the observance of the technical data and the installation and operating instructions in this manual.

2.4 Non-Intended Use



⚠ WARNING

Extraction of hazardous media, liquids or bulk material

Personal injury or damage to property!

- ▶ Do not extract harmful media such as dust, oil mists, vapors, aerosols etc.
 - ▶ Do not extract aggressive gases or media such as acids, acid fumes, bases, biocides, disinfectants or detergents.
 - ▶ Do not extract liquids or bulk materials, e.g. granulates.
-

Schmalz accepts no liability for damages caused by non-intended usage of the ejector. In particular, the following are considered non-intended use:

- Use in potentially explosive atmospheres
- Use in medical applications
- Lifting people or animals

- Evacuation of objects that are in danger of imploding

2.5 Personnel Qualification

Unqualified personnel cannot recognize dangers and are therefore exposed to higher risks!

1. Only instruct qualified personnel to perform the tasks described in these operating instructions.
2. The product may only be operated by persons who have undergone appropriate training.
3. Assembly and maintenance work must only be carried out by qualified personnel.

The following target groups are addressed in these operating instructions:

- Installers who are trained in handling the product and can operate and install it
- Technically trained service personnel performing the maintenance work

2.6 Modifications to the Ejector

Schmalz assumes no liability for consequences of modifications over which it has no control:

1. The ejector must be operated only in its original condition as delivered.
2. Use only original spare parts from Schmalz.
3. The ejector must be operated only in perfect condition.

3 Product description

3.1 Description of the Ejector

3.1.1 Suction of the Workpiece (Vacuum Generation)

In the NO (normally open) version, the Venturi nozzle is continuously sucking. As soon as compressed air is present at the ejector, the Venturi nozzle becomes active and the ejector generates a vacuum (suction). As soon as there is no compressed air at the ejector, the Venturi nozzle is deactivated.

The ejector has an integrated, pneumatically controlled, air saving function and automatically regulates the vacuum in Suction mode:

- The integrated, pneumatically controlled, air saving function switches off the Venturi nozzle as soon as the set vacuum limit value, deactivation value A, has been reached (factory setting).
- When objects with dense surfaces are picked up, the integrated non-return valve prevents the vacuum from dropping.
- If the system vacuum drops below the activation limit value E due to leaks, the Venturi nozzle is switched back on.

The air saving function is integrated in the ejector via a pneumatic controller. The limit values A and E cannot be changed.



If small volumes are to be evacuated, the set deactivation value A might be exceeded considerably before the vacuum is switched off. This system behavior does not constitute an error.

3.1.2 Depositing the Workpiece (Blowing Off)

In Blow off mode, the vacuum circuit of the ejector is supplied with external compressed air at the corresponding compressed air connection. This ensures that the vacuum drops quickly, depositing the workpiece quickly as well.



NOTE

Compressed air at both compressed air connections at the same time

Damage to the ejector

- ▶ Do not apply compressed air to both compressed air connections at the same time!

When blowing off, make sure that the compressed air supply for vacuum generation is switched off.

3.1.3 Pneumatic Air Saving Function

The ejector includes a pneumatically operated air saving function. When compressed air is applied to compressed air connection 1 (> See *ch. (See chap. Ejector structure)*), the ejector automatically controls the vacuum. When the set deactivation value A is reached, the ejector switches off the Venturi nozzle. If the system vacuum drops below the activation value E due to leaks, the Venturi nozzle is switched back on.

The following diagram shows the air saving function.

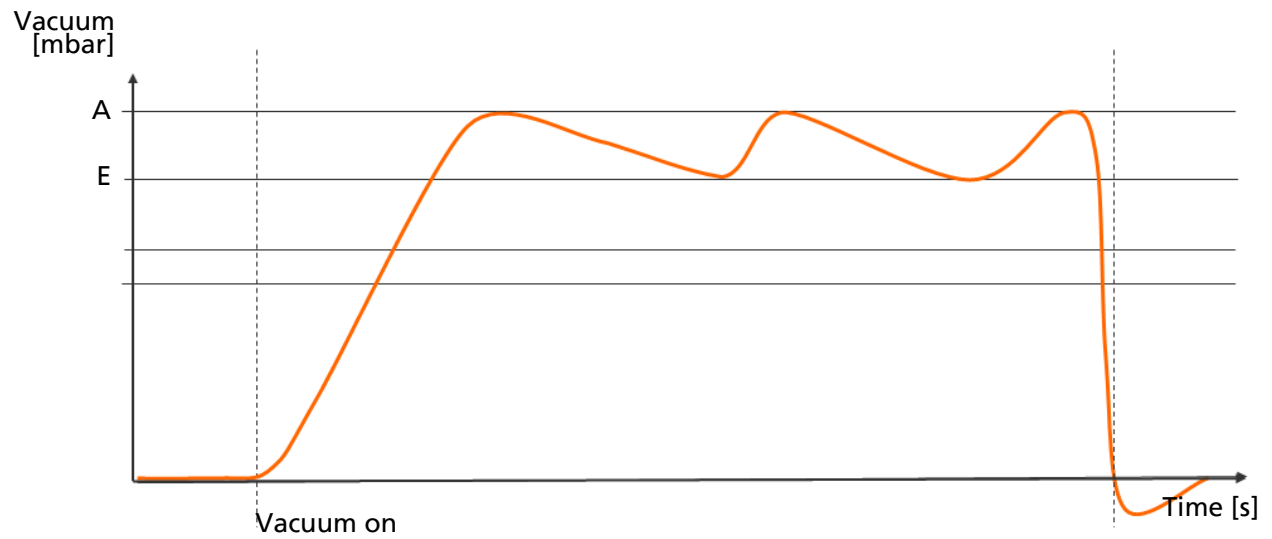

3.2 Ejector Designation

The breakdown of the item designation (e.g. SCPb 15 FS RP) is as follows:

Feature	Specifications
Type of ejector	SCPb
Nozzle size	1.5 mm
Type of external control	Externally controlled FS
Type of internal control	Pneumatically controlled RP

3.3 Ejector Structure

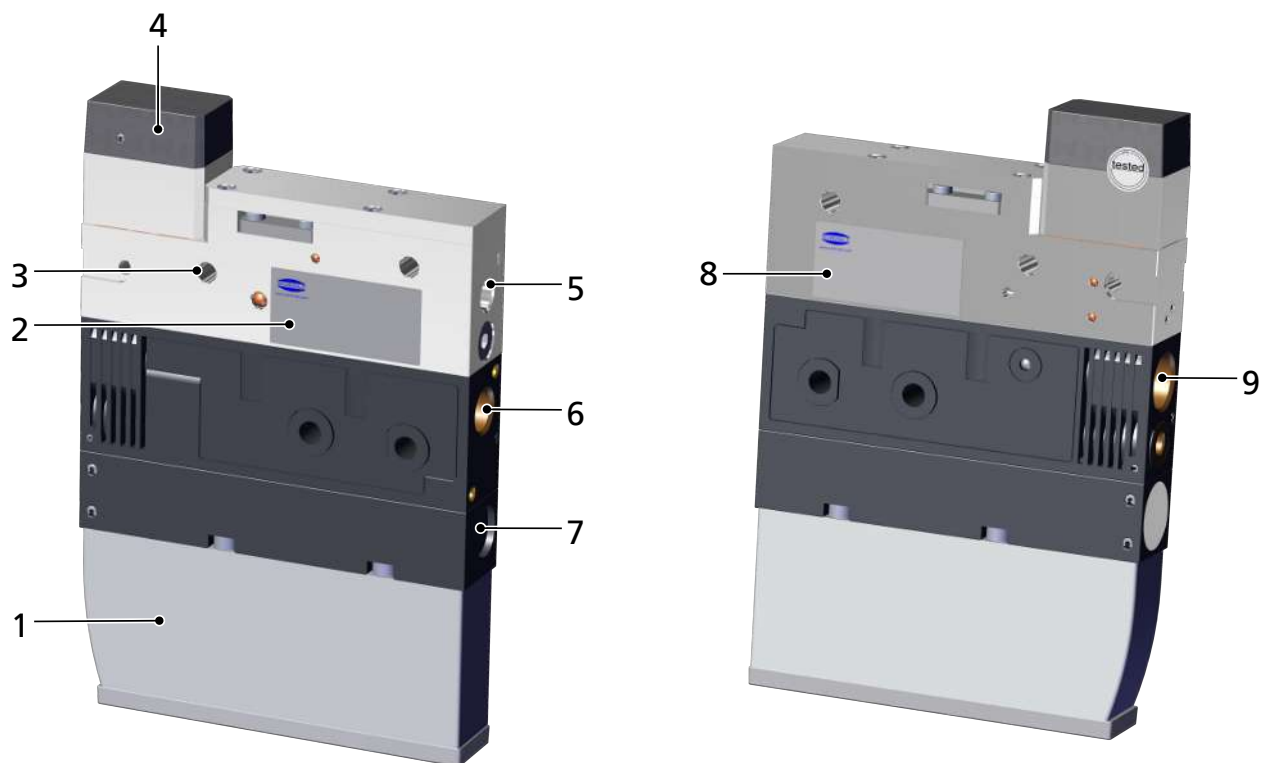

1	Silencer	2	Type plate 1
3	4x mounting holes	4	Position of pneumatic controller
5	Compressed air connection 1A (blow off)	6	Compressed air connection 1 (suction)
7	Bypass for exhaust air	8	Type plate 2
9	Vacuum connection 2		

4 Technical Data

4.1 General Parameters

Parameter	Symbol	Limit value			Unit	Note
		min.	typ.	max.		
Working temperature	T _{amb}	5	--	50	°C	--
Storage temperature	T _{Sto}	-10	--	60	°C	--
Humidity	H _{rel}	10	--	90	% r.h.	Free from condensation
Operating pressure	p	4	4.2	7	bar	--
Operating medium	Air or neutral gas, 5 µm filtered, with or without oil, class 3-3-3 compressed air quality in acc. with ISO 8573-1					

4.2 Mechanical Data

4.2.1 Performance Data

Version	SCPb-15	SCPb-20	SCPb-25
Nozzle size	1.5 mm	2.0 mm	2.5 mm
Max. vacuum ¹ [%]	870		
Suction rate ¹ [l/min]	75	135	185
Max. blow off capacity ¹ [l/min]	300		
Air consumption ¹ [l/min]	115	190	290
Air consumption for blow off ¹ [l/min]	310		
Sound level ¹ , unobstructed suction [dBA]	75		
Sound level ¹ , suction [dBA]	72		
Weight [kg]	0.64		

All values at ambient conditions of T = 20° C and 1000 mbar ambient pressure

¹⁾ at 4.5 bar

4.2.2 Factory Settings

In the factory setting,

Part no.	Activation value E [mbar]
10.02.02.05560	-630
10.02.02.05561	
10.02.02.05562	

4.2.3 Dimensions

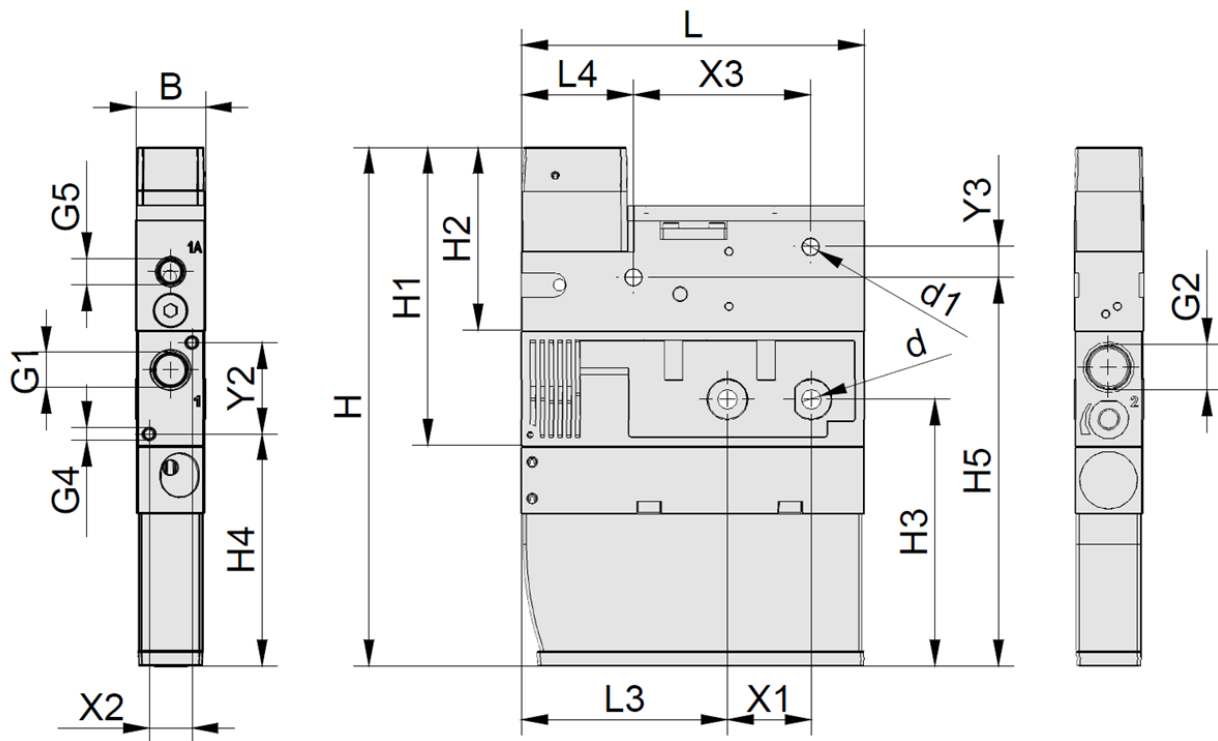

B	d	d1	G1	G2	G4	G5	H	H1	H2	H3
22.8	6.6	5.5	G1/4"-IG	G3/8"-IG	M4-IG	G1/8"-IG	170	98	460	87.5
H4	H5	L	L3	L4	X1	X2	X3	Y2	Y3	
76	127.5	112	67.5	36.75	27.5	14	58	30	10	

All specifications are in mm

4.2.4 Pneumatic Circuit Plan

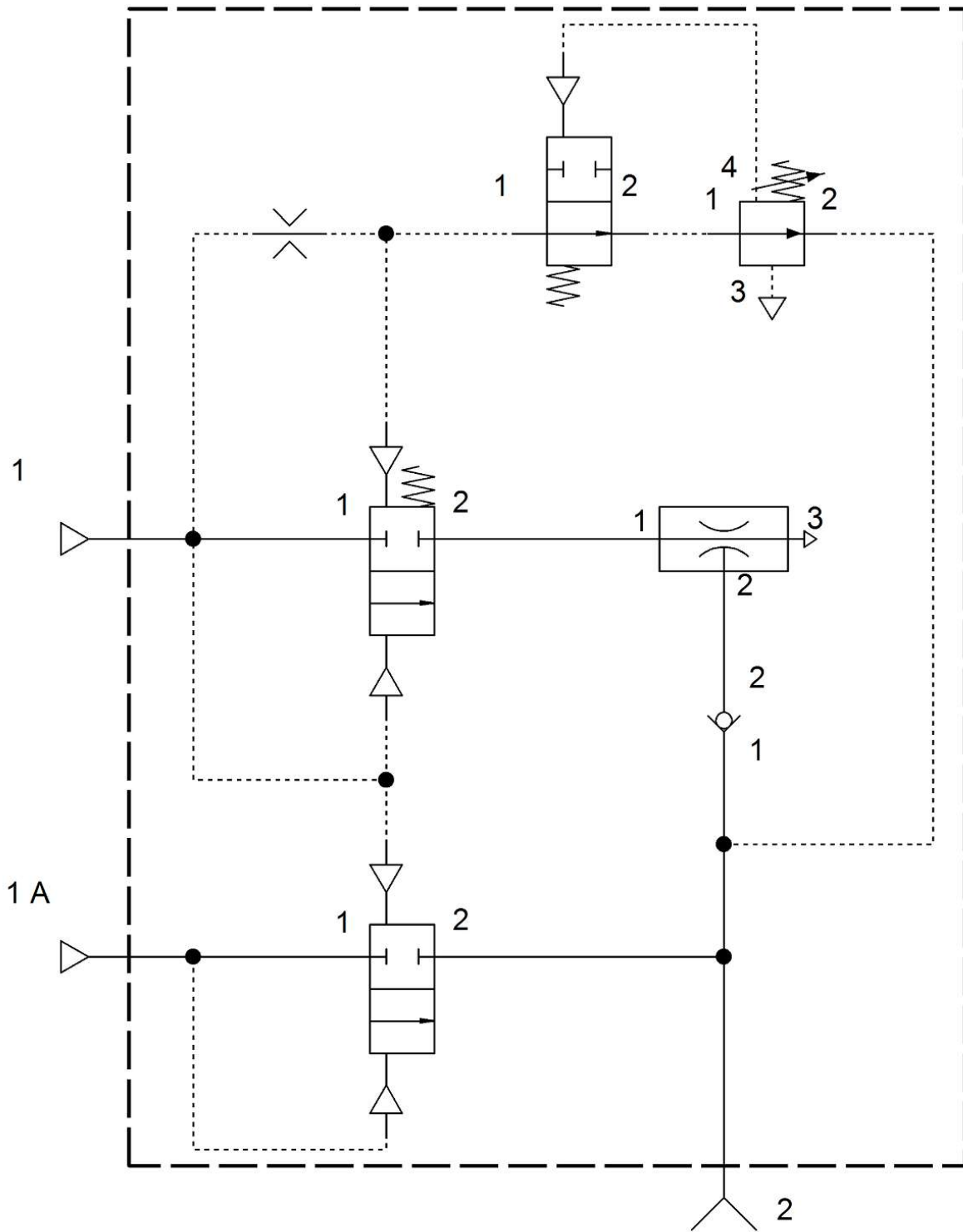

5 Transport and storage

5.1 Checking the Delivery

The scope of delivery can be found in the order confirmation. The weights and dimensions are listed in the delivery notes.

1. Compare the entire delivery with the supplied delivery notes to make sure nothing is missing.
2. Damage caused by defective packaging or in transit must be reported immediately to the carrier and J. Schmalz.

6 Installation

6.1 Installation Instructions



CAUTION

Improper installation or maintenance

Personal injury or damage to property

- ▶ During installation and maintenance, make sure that the ejector is disconnected and depressurized and that it cannot be switched on again without authorization.

For safe installation, the following instructions must be observed:

1. Use only the connections, mounting holes and attachment materials that have been provided.
2. Carry out mounting and removal only when the device is in an idle, depressurized state.
3. Pneumatic and electrical line connections must be securely connected and attached to the ejector.

6.2 Installation

The ejector may be installed in any position.

When installing the ejector, make sure that the areas around the silencer and the bypass remain free, so that unimpeded discharge of the escaping air is ensured.

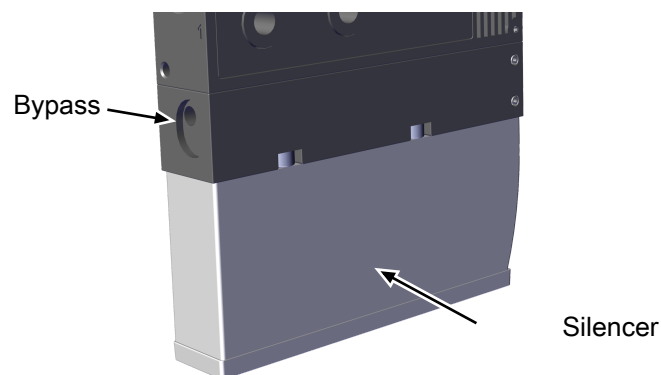

Four mounting holes for 2x M5 and 2x M6 screws are used to fix the ejector. The ejector is to be fixed with at least 2 screws, the maximum tightening torque is 6 Nm.

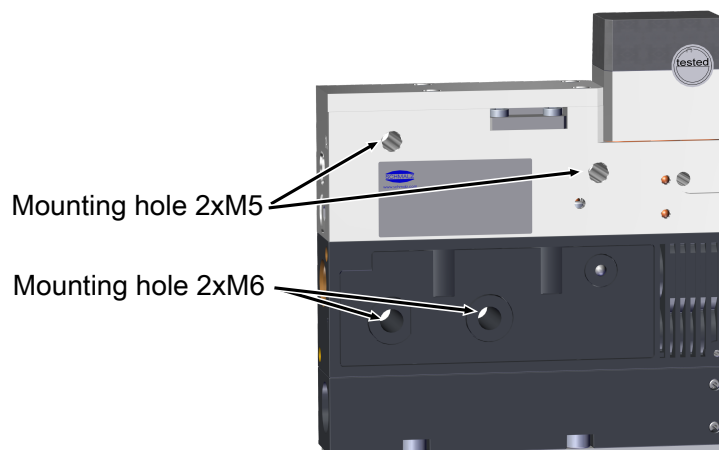

The compressed air required to generate the vacuum and the blow off is connected via the corresponding compressed air connections. The compressed air supply must be supplied by the higher-level machine.
 The vacuum circuit or gripping system is connected to the vacuum connection.
 The installation process is described and explained in detail below.

6.3 Pneumatic Connection



⚠ CAUTION

Compressed air or vacuum in direct contact with the eye

Severe eye injury

- ▶ Wear eye protection
- ▶ Do not look into compressed air openings
- ▶ Do not look into the silencer air stream
- ▶ Do not look into vacuum openings, e.g. suction cups



⚠ CAUTION

Noise pollution due to incorrect installation of the pressure and vacuum connections

Hearing damage

- ▶ Correct installation.
- ▶ Wear ear protectors.

6.3.1 Connecting the Compressed Air and Vacuum

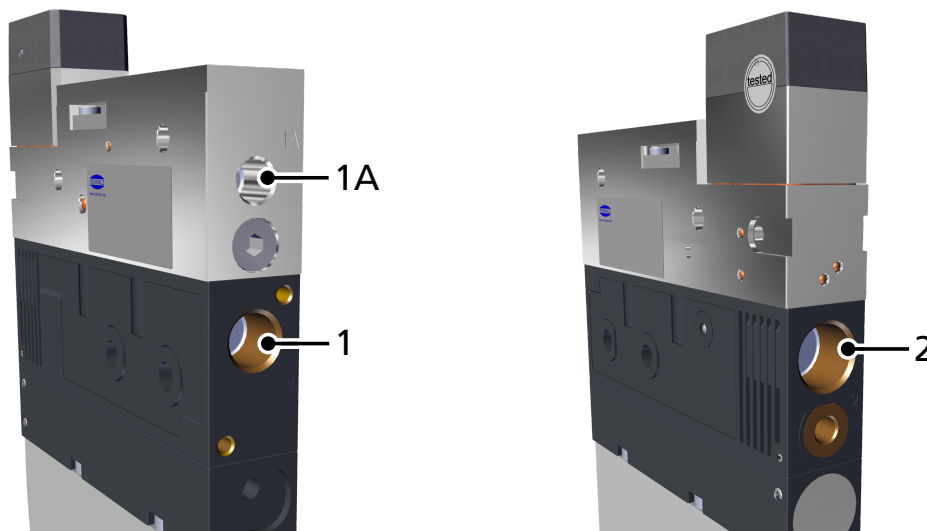

1	Compressed air connection (suction)
1A	Compressed air connection (blow off)
2	Vacuum connection

The compressed air connection 1 on the ejector has the size G1/4"-IG.

- ▶ Connect compressed air hose. The max. tightening torque is 10 Nm.

The compressed air connection 1A on the ejector has the size G1/8"-IG.

- ▶ Connect compressed air hose. The max. tightening torque is 10 Nm.

The vacuum connection G3/8"-IG is marked with the number 2 on the ejector.

- ▶ Connect vacuum hose. The max. tightening torque is 10 Nm.

6.3.2 Instructions for the Pneumatic Connection

Use only screw unions with cylindrical G-threads for the compressed air and vacuum connection!

To ensure problem-free operation and a long service life of the ejector, only use adequately maintained compressed air and consider the following requirements:

- Use of air or neutral gas in accordance with EN 983, filtered 5 µm, oiled or unoiled.
 - Dirt particles or foreign bodies in the ejector connections, hoses or pipelines can lead to partial or complete ejector malfunction.
1. Shorten the hoses and pipelines as much as possible.
 2. Keep hose lines free of bends and crimps.
 3. Only use a hose or pipe with the recommended internal diameter to connect the ejector, otherwise use the next largest diameter.
 4. On the compressed air side, ensure that the internal diameter has the necessary specifications so that the ejector achieves its performance data.
 5. On the vacuum side, ensure that the internal diameter has the necessary specifications to avoid high flow resistance. If the internal diameter is too small, the flow resistance and the evacuation times increase and the blow off times are extended.

The following table shows the recommended line cross-sections (internal diameter):

Performance class	Line cross-section (internal diameter) in mm ¹⁾	
	pressure side	Vacuum side
15	6	6
20	6	8
25	8	9

¹⁾Based on a maximum hose length of 2 m.

- ▶ For longer hose lengths, the cross-sections must also be larger.

7 Operation

7.1 General Preparations



⚠ WARNING

Extraction of hazardous media, liquids or bulk material

Personal injury or damage to property!

- ▶ Do not extract harmful media such as dust, oil mists, vapors, aerosols etc.
 - ▶ Do not extract aggressive gases or media such as acids, acid fumes, bases, biocides, disinfectants or detergents.
 - ▶ Do not extract liquids or bulk materials, e.g. granulates.
-

Always carry out the following tasks before activating the system:

1. Before each use, check that the safety devices are in perfect condition.
2. Check the ejector for visible damage and deal with any problems immediately (or notify your supervisor).
3. Ensure that only authorized personnel are present in the working area of the machine or system and that no other personnel are put in danger by switching on the machine.

There must be no people in the system danger area while it is in operation.

8 Help with Malfunctions

Fault	Cause	Measure
Ejector does not respond	No compressed air supply	▶ Check the compressed air supply
Vacuum level is not reached or vacuum is built up too slowly	Press-in screen is contaminated	▶ Replace screen
	Silencer is soiled	▶ Replace silencer insert
	Leakage in hose line	▶ Eliminate leakage from hose connections
	Leakage at suction cup	▶ Eliminate leakage from suction cup
	Operating pressure too low	▶ Increase operating pressure, observe maximum limits
	Internal diameter of hose line too small	▶ Observe recommendations for hose diameter
Load cannot be held	Vacuum level too low	▶ Increase the control range for the air saving function
	Suction cup too small	▶ Select a larger suction cup

9 Maintenance

9.1 Safety

Maintenance work may only be carried out by qualified personnel.



WARNING

Risk of injury due to incorrect maintenance or troubleshooting

- ▶ Check the proper functioning of the product, especially the safety features, after every maintenance or troubleshooting operation.



NOTE

Incorrect maintenance work

Damage to the ejector!

- ▶ Always switch off supply voltage before carrying out any maintenance work.
- ▶ Secure before switching back on.
- ▶ The ejector must only be operated with a silencer and press-in screens.

- ▶ Create atmospheric pressure in the ejector's compressed air circuit before working on the system!

9.2 Cleaning the Ejector

1. For cleaning, do not use aggressive cleaning agents such as industrial alcohol, white spirit or thinners. Only use cleaning agents with pH 7–12.
2. Remove dirt on the exterior of the device with a soft cloth and soap suds at a maximum temperature of 60° C. Make sure that the silencer is not soaked in soapy water.

10 Warranty

This system is guaranteed in accordance with our general terms of trade and delivery. The same applies to spare parts, provided that these are original parts supplied by us.

We are not liable for any damage resulting from the use of non-original spare parts or accessories.

The exclusive use of original spare parts is a prerequisite for the proper functioning of the ejector and for the validity of the warranty.

Wearing parts are not covered by the warranty.

Opening the ejector will damage the "tested" labels. This voids the warranty.

11 Spare and Wearing Parts

Maintenance work may only be carried out by qualified personnel.



⚠ WARNING

Risk of injury due to incorrect maintenance or troubleshooting

- ▶ Check the proper functioning of the product, especially the safety features, after every maintenance or troubleshooting operation.

The following list contains the primary spare and wearing parts.

Part no.	Designation	Legend
10.02.02.03381	Silencer insert	W

Legend:

- **Wearing part = W**
- ▶ When tightening the fastening screws on the silencer module, observe the maximum tightening torque of 0.4 Nm.

12 Decommissioning and recycling

12.1 Disposing of the Ejector

1. Dispose of the product properly after replacement or decommissioning.
2. Observe the country-specific guidelines and legal obligations for waste prevention and disposal.

12.2 Materials Used

Component	Material
Housing	PA6-GF, PC-ABS, AL
Inner components	Aluminum alloy, anodized aluminum alloy, brass, galvanized steel, stainless-steel, PU, POM
Silencer insert	Porous PE
Screws	Galvanized steel
Sealing	Nitrile rubber (NBR)
Lubrication	Silicone-free
Piston	Stainless steel (1.4435 BN II)
Gasket	VMQ – 65 Shore (FDA 177.2600-21)

13 Appendix

See also

 SCPb_CEE_30.30.01.01874_00_DE-EN-FR-ES-IT-NL.pdf [[▶ 25](#)]

DE EU-Einbauerklärung
EN EC declaration of incorporation
FR Déclaration d'incorporation CE
ES Declaración CE de montaje
IT Dichiarazione di montaggio CE
NL EG-inbouwverklaring



Hersteller / Manufacturer / Fabricant / Fabricante / Produttore / Fabrikant

J. Schmalz GmbH, Johannes-Schmalz-Str. 1, D - 72293 Glatten

Produktbezeichnung / Product name / Designation du produit /
Denominación del producto / Denominazione del prodotto /
Beschrijving van de machine

SCPb_FS RP

Ejektoren der Serie / Ejectors series / Ejecteurs de la série /
Eyectores de la serie / Eiettori de la serie / Ejector Serie

Das bezeichnete Produkt ist ausschließlich zum Einbau in eine andere Maschine bestimmt. Die Inbetriebnahme ist so lange untersagt, bis die Konformität des Endproduktes mit der Richtlinie 2006/42/EG festgestellt wurde. / The product specified is solely intended for installation in another machine. Startup is prohibited until the end product has been declared to comply with the Directive 2006/42/EC. / Le produit désigné est conçu exclusivement pour être installé dans une autre machine. La mise en service est interdite jusqu'à ce qu'il a été constaté que le produit final est conforme à la directive 2006/42/CE. / El producto indicado se ha concebido únicamente para el montaje en otra máquina. La puesta en servicio queda prohibida hasta que se establezca la conformidad del producto final con la Directiva 2006/42/CE. / Il prodotto identificato è destinato esclusivamente al montaggio in un'altra macchina. La messa in funzione è proibita finché non è stata accertata la conformità del prodotto finito alla direttiva 2006/42/CE. / Het genoemde product is uitsluitend voor het inbouwen in een andere machine bedoeld. De inbedrijfstelling is niet toegestaan totdat de conformiteit van het eindproduct met de richtlijn 2006/42/EG is vastgesteld. /

Erfüllte einschlägige EU-Richtlinien / Applicable EC directives met / Directives CE applicables respectées / Directivas vigentes de la CE cumplidas /
Direttive CE applicate ed osservate / Nagekomen betreffende EG-richtlijnen

2006/42/EG Maschinenrichtlinie / Machinery Directive / Directive sur les machines / Directiva para máquinas / Direttiva macchine /
Machinerichtlijn / Diretiva máquinas

Angewendete harmonisierte Normen / Harmonised standards applied / Normes d'harmonisation appliquées /
Normas armonizadas aplicadas / Norme armonizzate adottate / Toegepaste geharmoniseerde normen

EN ISO 12100: 2011-03 Sicherheit von Maschinen - Allgemeine Gestaltungsleitsätze - Risikobeurteilung und Risikominderung / Safety of
Machinery - General principles for design - Risk assessment and risk reduction / Sécurité des machines - Principes
généraux de conception - Appréciation du risque et réduction du risque / Seguridad de máquinas - Principios generales de
diseño - Evaluación del riesgo y reducción del riesgo / Sicurezza delle macchine - Principi generali di progettazione -
Valutazione del rischio e riduzione del rischio / Veiligheid van machines - Algemene beginselen voor ontwerp -
Risicobeoordeling en de risicoreductie

Der Hersteller verpflichtet sich, die speziellen Unterlagen zur unvollständigen Maschine einzelstaatlichen Stellen auf Verlangen elektronisch zu übermitteln. Die zur Maschine gehörenden speziellen technischen Unterlagen nach Anhang VII Teil B wurden erstellt. / The manufacturer is required to provide special documentation on the partly completed machinery to national authorities electronically on request. The special technical documentation in accordance with Annex VII Part B belonging to the machine has been created. / Le fabricant s'engage à envoyer par voie électronique les documents spéciaux sur la machine incomplète aux organes nationaux sur demande. Les documents techniques spéciaux concernant la machine ont été établis conformément à l'annexe VII, section B. / El fabricante se compromete a facilitar por medios electrónicos la documentación especial de la máquina incompleta a los organismos estatales cuando éstos la requieran. La documentación técnica especial perteneciente a la máquina se ha elaborado según el anexo VII parte B. / Il costruttore si impegna a trasmettere elettronicamente su richiesta la documentazione speciale di macchine incomplete alle autorità nazionali. I documenti tecnici speciali appartenenti alla macchina secondo l'appendice VII, sezione B sono stati redatti. / De fabrikant is verplicht de speciale documentatie bij de onvolledige machine, indien in het betreffende land gewenst, elektronisch over te dragen. De bij de machine horende speciale technische documentatie conform bijlage VII deel B is opgeemaakt.

Dokumentationsverantwortlicher / Person responsible for documentation / Responsable de la documentation / Responsable de documentaci3n /
Responsabile della documentazione / Verantwoordelijk voor de documentatie

Glatten, 14.11.2018

/ i.A.



Klaus-Dieter Fanta / J. Schmalz GmbH, Johannes-Schmalz-Str. 1, D - 72293 Glatten

Unterschrift, Angaben zum Unterzeichner / Signature, details of signatory / Signature, indications sur le soussigné /
Firma y datos del firmante / Firma, dati concernenti il firmatario / Handtekening, omschrijving van de ondertekenaar

Glatten, 14.11.18

/

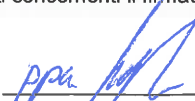

Walter Dunkmann
Leiter Geschäftsfeld, Vakuum-Automation /
Head of Business Unit, Vacuum Automation

At your side worldwide

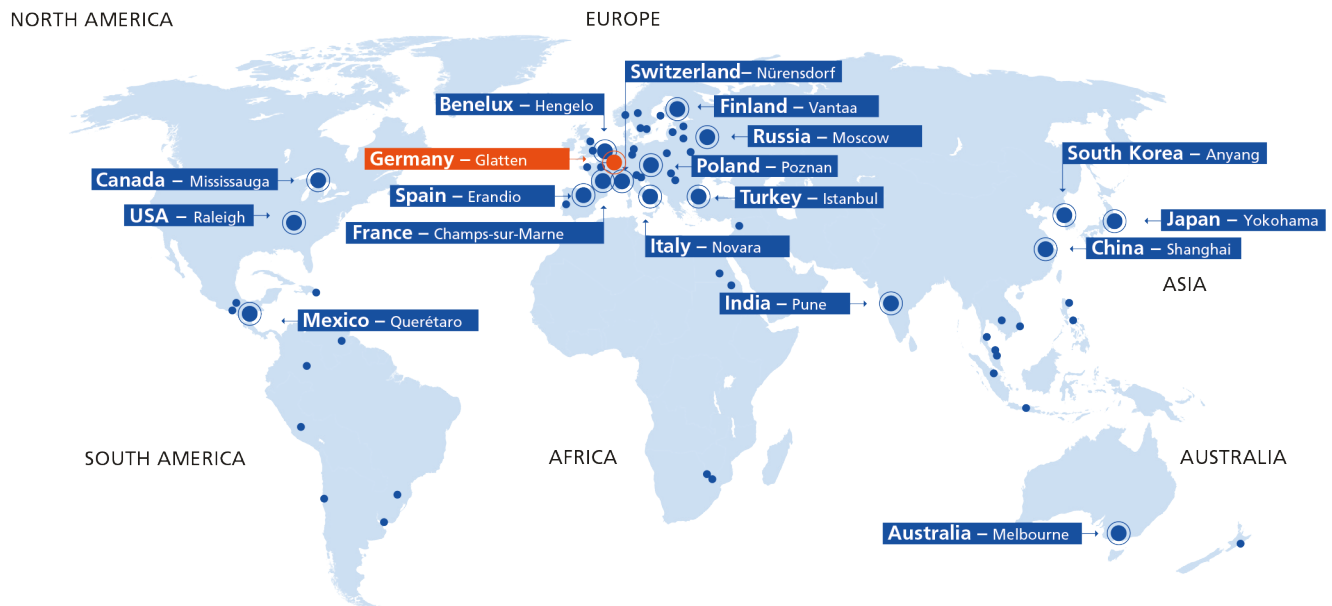

Headquarters

Schmalz Germany – Glatten

Sales Partners

You can find the Schmalz sales partner in your country at:
WWW.SCHMALZ.COM/SALESNETWORK

Subsidiaries

- Schmalz Australia – Melbourne
- Schmalz Benelux – Hengelo (NL)
- Schmalz Canada – Mississauga
- Schmalz China – Shanghai
- Schmalz Finland – Vantaa
- Schmalz France – Champs-sur-Marne
- Schmalz India – Pune
- Schmalz Italy – Novara
- Schmalz Japan – Yokohama

- Schmalz Mexico – Querétaro
- Schmalz Poland – Suchy Las (Poznan)
- Schmalz Russia – Moscow
- Schmalz South Korea – Anyang
- Schmalz Spain – Erandio (Vizcaya)
- Schmalz Switzerland – Nürens Dorf
- Schmalz Turkey – Istanbul
- Schmalz USA – Raleigh (NC)

Vacuum Automation

WWW.SCHMALZ.COM/AUTOMATION

Handling Systems

WWW.SCHMALZ.COM/HANDLINGSYSTEMS

J. Schmalz GmbH
Johannes-Schmalz-Str. 1
72293 Glatten, Germany
T: +49 7443 2403-0
schmalz@schmalz.de
WWW.SCHMALZ.COM