

SWIVEL

HF



Features

- For tables such as TV monitors and worktables.
- Rubber stoppers prevent from slipping.
- Top plate has holes to fix on table.

Remarks

- Mounting hole pitch may vary. Please check with the actual item.

Application Example

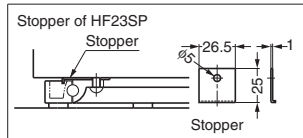
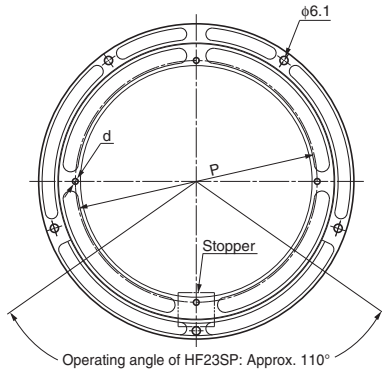
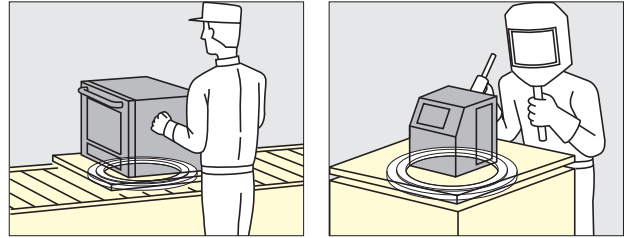

\*Stopper can be removed.

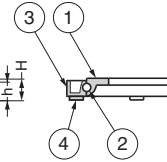
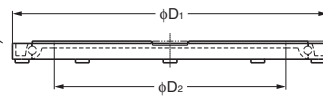

No.	Part Name	Material	Finish/Colour
①	Top Plate	Aluminium Alloy	As below
②	Balls	Steel	-
③	Base Plate	Aluminium Alloy	As below
④	Leg	Rubber	White

Item Code	Item Name	Stopper	Finish	D <sub>1</sub>	D <sub>2</sub>	P	H	h	d	Holes	Load Capacity	Weight	Box	
210-035-222	HF23SP	With	Polished	230	166	176	16	15	φ4.8	4	392 N	40 kgf	0.37 kg	40 pcs
210-035-220	HF30	Without	Polished	327	265	275.5	16	15	φ4.8	6	588 N	60 kgf	0.55 kg	20 pcs
210-035-221	HF45	Without	Polished	441	380	392	22	16.5	φ4.8, φ10 CSK	6	980 N	100 kgf	1.60 kg	10 pcs
210-035-226	HF60	Without	Silver	600	520	538	24	18.5	φ4.8, φ12 CSK	4	1960 N	200 kgf	3.20 kg	5 pcs

Operating angle of HF23SP: Approx. 110°

MISCELLANEOUS

SWIVEL / MULTI ANGLE STAY

MULTI ANGLE STAY

KA-60

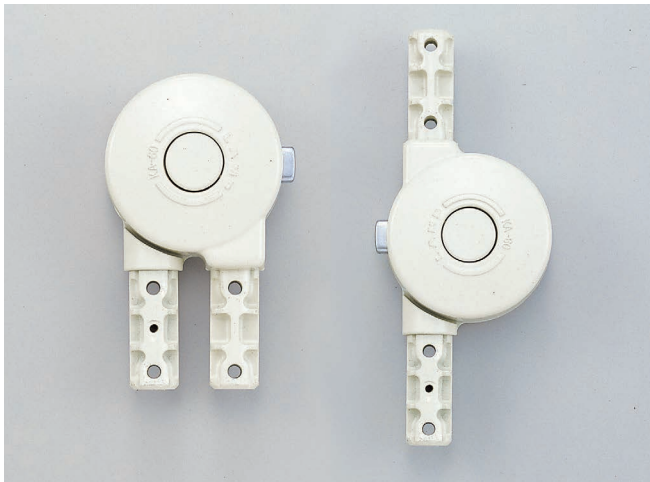

Features

- Angle adjustment and locking is realised by simple button operation.
- Suitable for pipe joints for which angle adjustment is required.
- Angle can be adjusted from 0° - 180° by 10° increments.
- Completely locked when your hands are off the release button.

Remarks

- Do not forcibly apply force in the locked position.
- Pipe not included.

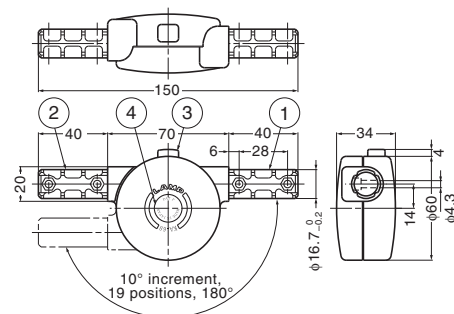

Installation Example

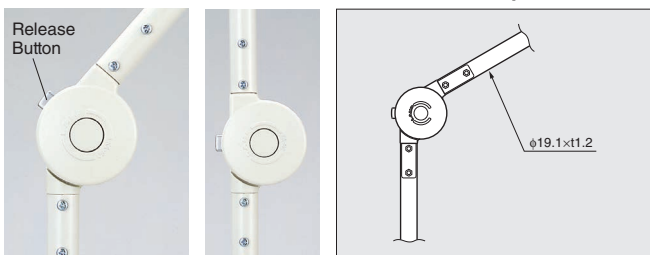

Pipe Cut Out Dimensions

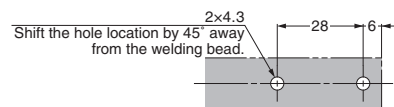

Item Code	Item Name	Applicable Pipe	Load Capacity	Weight	Box	Carton
170-890-570	KA-60	φ19.1x1.2	14 N·m	1.4 kgf·m	170 g	6 pcs

No.	Part Name	Material	Finish
①	Body A	Aluminium Alloy	Ivory
②	Body B	Aluminium Alloy	Ivory
③	Release Button	Aluminium Alloy	Chrome
④	Cap	ABS	Black