

BASE

HS-550



Features

- Recommended Caster : FA55N (P.743) for HS-550M10, EX-100N (P.757) for HS-550M12
- For $\phi 38.1$ pipe.

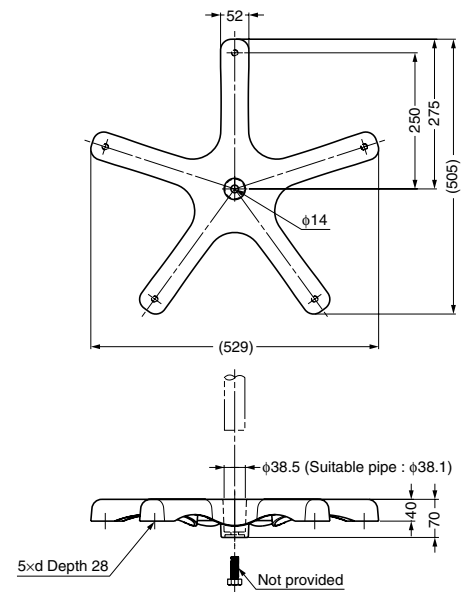

CASTERS & LEVELING GLIDES

BASE

Application Example

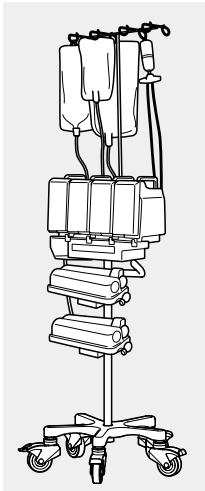

Caster (Sold Separately)

EX-100N (P.757)

FA55N (P.743)



Weight for Base (Optional Parts)

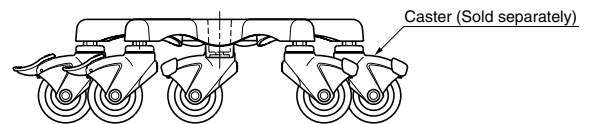

Installation of Optional Weight for Base

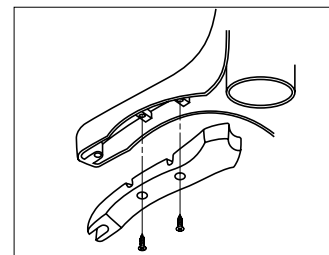

Recommended Screw : Hexagon socket head cap screw M5x15

Base

Item Code	Item Name	Material	Finish	d	Weight	Carton
200-013-966	HS-550M10W	Aluminium Alloy (ADC)	Paint/White	M10	2.2 kg	5 pcs
200-012-545	HS-550M12W	Aluminium Alloy (ADC)	Paint/White	M12	2.2 kg	5 pcs
200-017-128	HS-550M10M	Aluminium Alloy (ADC)	Mirror	M10	2.2 kg	5 pcs
200-014-984	HS-550M12M	Aluminium Alloy (ADC)	Mirror	M12	2.2 kg	5 pcs

Weight for Base (Optional Parts)

Item Code	Item Name	Material	Finish	Weight	Carton
200-021-233	HSW-2	Steel (FC)	Paint/White	1.8 kg	1 pc