

SLIDING DOOR ROLLER JC115 L Type w/ Bracket

Made to Order

LOAD CAPACITY 6370~24500 N



JC115-100L

- Bearing with rubber seal (dustproof seal type) provides excellent water resistance.
- Ideal for exterior application.
- 2 bearings are used for wheel, providing smooth movement even for heavy doors.
- Gap between bracket and wheel absorbs deformation and allows for smooth movement.

[Applications]

- Gates, etc.

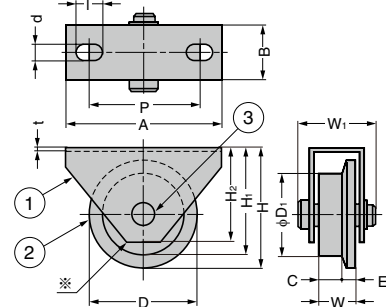

※JC115-75L shown. Brackets other than above are of the same shape as the picture.

[Application Example]

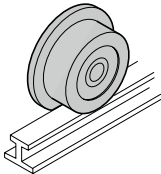

No.	Part Name	Material	Finish
①	Bracket	Steel (SPHC)	Clear Zinc Chromate
②	Wheel	Ductile Cast Iron	Black Enamel Finish
③	Bearing	-	-

RoHS	CAD	Item Code	Item Name	D	D ₁	W	W ₁	A	B	C	E	H	H ₁	H ₂	d	l	P	t	Load Capacity N/2 pcs	Load Capacity kgf/2 pcs	Weight (kg)	Box (pcs)	Carton (pcs)
☑	3D	200-024-833	JC115-75L	90	75	32	52	120	42.5	24	8	95.5	88	67	11	15	94	3.2	6370	650	1.3	1	10
☑	3D	200-024-834	JC115-100L	120	100	36	57	145	47	26	10	125	115	90					11760	1200	2.3	1	6
☑	3D	200-024-835	JC115-150L	150	130	43	88	250	60	33		165	155	137					21560	2200	6	1	4
☑	3D	200-024-836	JC115-200L	200	170	50	105	290	70	36.5	13.5	215	200	160	20	35	185	6	24500	2500	10.5	1	2

SLIDING DOOR ROLLER JC120 L Type w/o Bracket

Made to Order



- Non-bracket type of JC115 1.
- Bearing with rubber seal (dustproof seal type) provides excellent water resistance.
- Ideal for exterior application.
- 2 bearings are used for wheel, providing smooth movement even for heavy doors.

[Applications]

- Gates, etc.

[Remarks]

- Core rod for wheel diameter ϕ90~ϕ120 is not grooved for E-ring. Core rod for ϕ150~ϕ200 consists of one bolt and one nut.
- The shape of core rod varies depending on its size. Please confirm with the figure below.

[Parts Included]

- Wheel shaft

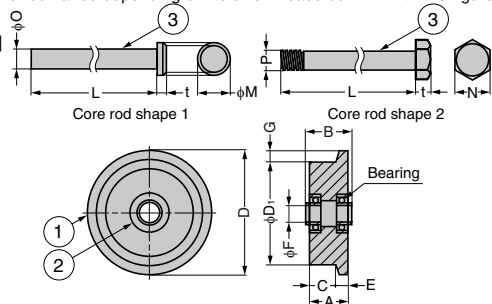

[Application Example]

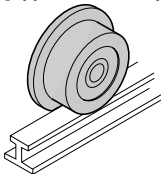

No.	Part Name	Material	Finish
①	Wheel	Ductile Cast Iron	Black Enamel Finish
②	Bearing	-	-
③	Core Rod	Steel (SWCH)	-

RoHS	CAD	Item Code	Item Name	D	D ₁	A	B	C	E	F	G	L	M	N	O	P	t	Weight (kg)	Core Rod Shape	Box (pcs)	Carton (pcs)
☑	3D	200-024-837	JC120-75L	90	75	32	36	24	8	13	7.5	75	19	-	12.9	-	6.3	0.9	1	1	20
☑	3D	200-024-838	JC120-100L	120	100	36	40	26	10	16	10	100	24	-	15.9	-	5	1.7	1	1	20
☑	3D	200-024-839	JC120-150L	150	130	43	48	33				100	30	-	M20	13	3.3		1	1	4
☑	3D	200-024-840	JC120-200L	200	170	50	58	36.5	13.5	24	15	136	36	-	M24	15	6.5		1	1	2

Refer to 1 : P.800