

TWIN WHEEL CASTER (PLATE TYPE)

BR-20P, BR-25P

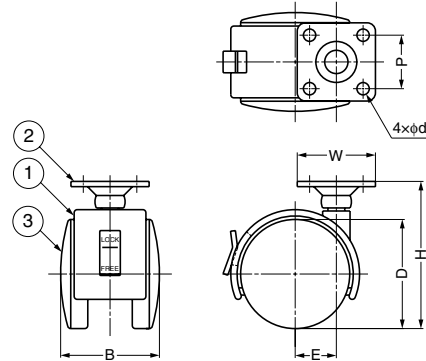

No.	Part Name	Material	Finish/Colour
①	Body	Polyamide (PA)	Black
②	Plate	Steel	Clear Zinc Chromate
③	Wheel	Polyamide (PA)	Black

Item Code	Item Name	Type	D	H	B	W	P	E	d	Load Capacity N	Load Capacity kgf	Weight	Carton
200-132-028	BR-20PS	With Brake	45	61.5	42	38	26	16	6	294 N	30 kgf	104 g	200 pcs
200-132-022	BR-20P	Without Brake	45	61.5	42	38	26	16	6	294 N	30 kgf	95 g	200 pcs
200-132-038	BR-25PS	With Brake	53	71.5	48	38	26	20	6	392 N	40 kgf	149 g	120 pcs
200-132-032	BR-25P	Without Brake	53	71.5	48	38	26	20	6	392 N	40 kgf	138 g	120 pcs

TWIN WHEEL CASTER (THREADED BOLT TYPE)

BR-20N, BR-25N

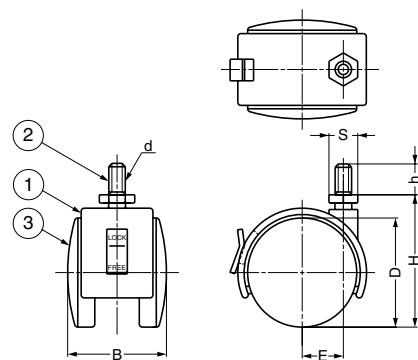
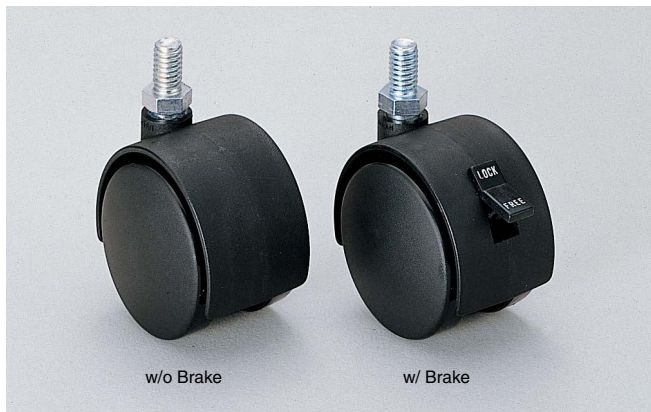

No.	Part Name	Material	Finish/Colour
①	Body	Polyamide (PA)	Black
②	Threaded Bolt	Steel	Clear Zinc Chromate
③	Wheel	Polyamide (PA)	Black

Item Code	Item Name	Type	D	H	h	B	E	S	d	Load Capacity N	Load Capacity kgf	Weight	Carton
200-132-026	BR-20N8S	With Brake	45	54	15	42	16	14	M8	294 N	30 kgf	79 g	200 pcs
200-132-020	BR-20N8	Without Brake	45	54	15	42	16	14	M8	294 N	30 kgf	69 g	200 pcs
200-132-036	BR-25N8S	With Brake	53	64	15	48	20	14	M8	392 N	40 kgf	117 g	150 pcs
200-132-030	BR-25N8	Without Brake	53	64	15	48	20	14	M8	392 N	40 kgf	106 g	150 pcs
200-132-037	BR-25N3S	With Brake	53	64	15	48	20	14	W3/8	392 N	40 kgf	119 g	150 pcs
200-132-031	BR-25N3	Without Brake	53	64	15	48	20	14	W3/8	392 N	40 kgf	108 g	150 pcs