

TWIN WHEEL CASTER T, TSD Threaded Bolt Type

LOAD CAPACITY 784~980 N

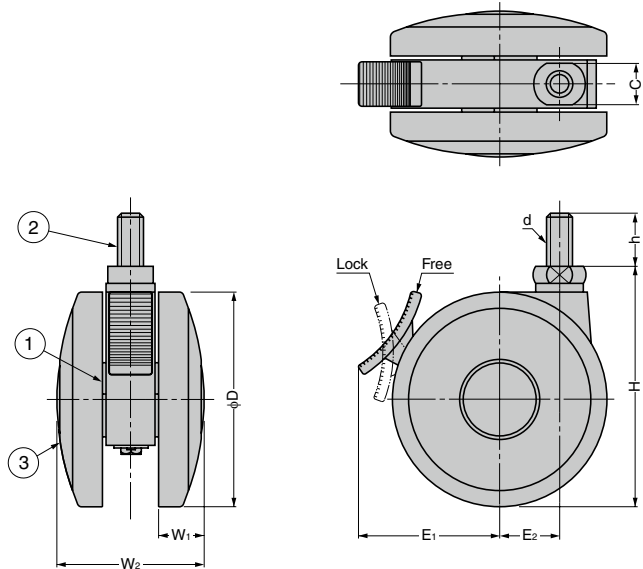

- Easy operation to lock on both wheel and swivel in one step.
- Wheels are coated in polyurethane which absorbs vibration and gives an extra smooth and quiet movement.



TSD-100B shown.

| No. | Part Name | Material | Finish/Colour |
|-----|---------------|----------|---------------------------------|
| ① | Body | PA | Light Grey |
| ② | Threaded Bolt | Steel | Clear Zinc Chromate (Trivalent) |
| ③ | Wheel | PA + PUR | Light Grey |

| RoHS | CAD | Item Code | Item Name | Type | D | W ₁ | W ₂ | H | h | E ₁ | E ₂ | C | d | Load Capacity N/pc | Load Capacity kg/pc | Weight (g) | Box (pcs) | Carton (pcs) |
|------|-----|-------------|-----------|---------------|-----|----------------|----------------|-------|----|----------------|----------------|----|------------|--------------------|---------------------|------------|-----------|--------------|
| CE | 3D | 200-130-169 | TSD-75B | With Brake | 76 | 19 | 61 | 86 | 20 | 45 | 21 | 17 | M10 | 784 | 80 | 260 | 60 | - |
| CE | 3D | 200-130-165 | T-75B | Without Brake | 76 | 19 | 61 | 86 | 20 | 45 | 21 | 17 | M10 | 784 | 80 | 240 | 60 | - |
| CE | 3D | 200-130-430 | TSD-100B | With Brake | 100 | 20 | 69 | 117.5 | 25 | 64 | 28 | 21 | M12 x 1.25 | 980 | 100 | 565 | 20 | - |
| CE | 3D | 200-130-168 | T-100B | Without Brake | 100 | 20 | 69 | 117.5 | 25 | 64 | 28 | 21 | M12 x 1.25 | 980 | 100 | 555 | 20 | - |

DESIGN CASTER FS Plate Type/Threaded Bolt Type

Made to Order **LOAD CAPACITY 490 N**

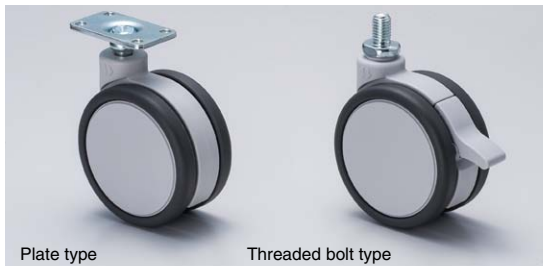

- 8 cover colours available.
- The cover is removable.
- With lock level to lock the wheel.
- Wheel diameter is $\phi 75$.
- Minimum order is 60 pcs.

[Remarks]

- Be careful not to scratch the cover when removing it.

[Colours]

