

## TWIN WHEEL CASTER T, TSD Plate Type

LOAD CAPACITY 784~980 N



- Easy operation to lock on both wheel and swivel in one step.
- Wheels are coated in polyurethane which absorbs vibration and gives an extra smooth and quiet movement.

HEAVY DUTY CASTERS

SINGLE WHEEL CASTERS

TWIN WHEEL CASTERS

CASTERS WITH LEVELLING GLIDES

BALL CASTERS

SLIDING DOOR ROLLERS

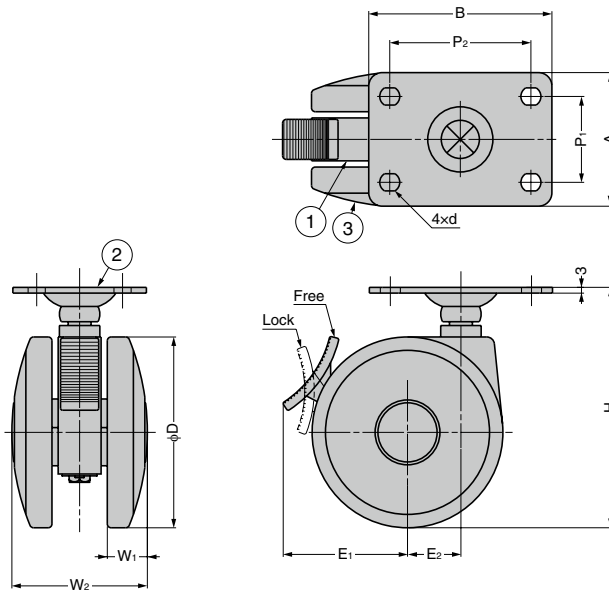

TSD-100P shown.

No.	Part Name	Material	Finish/Colour
①	Body	PA	Light Grey
②	Plate	Steel	Clear Zinc Chromate (Trivalent)
③	Wheel	PA + PUR	Light Grey

RdHS	CAD	Item Code	Item Name	Type	D	W <sub>1</sub>	W <sub>2</sub>	H	A	B	P <sub>1</sub>	P <sub>2</sub>	E <sub>1</sub>	E <sub>2</sub>	d φ	Load Capacity N/pc	Load Capacity kgf/pc	Weight (g)	Box (pcs)	Carton (pcs)
GD	3D	200-130-167	TSD-75P	With Brake	76	19	61	94	58	70	42	55	45	21	8.5	784	80	340	-	60
GD	3D	200-130-166	T-75P	Without Brake														320	-	60
GD	3D	200-130-431	TSD-100P	With Brake	100	20	69	126.5	70	96	45	74	64	28	9 × 10.5 Oval	980	100	710	-	20
GD	3D	200-130-432	T-100P	Without Brake														700	-	20