

# STAINLESS STEEL CASTER SUS-ET Threaded Bolt Type

**LOAD CAPACITY** 380~600 N

**SUS**

- Stainless steel (SUS304) body provides excellent corrosion resistance.
- Conductive rubber wheels also available.
- Anti-static urethane wheel with diameter  $\phi 100$  also available.

### [How to order] When installing caster to aluminium frame.

※Please select both caster (single item) and base installation parts set **1** and specify the item names of both.

※Refer to the relevant pages when ordering base **2** and AS nut **3** separately.

### [Sold Separately]

- Base installation parts set

### [Base Installation Parts Set] Sold Separately

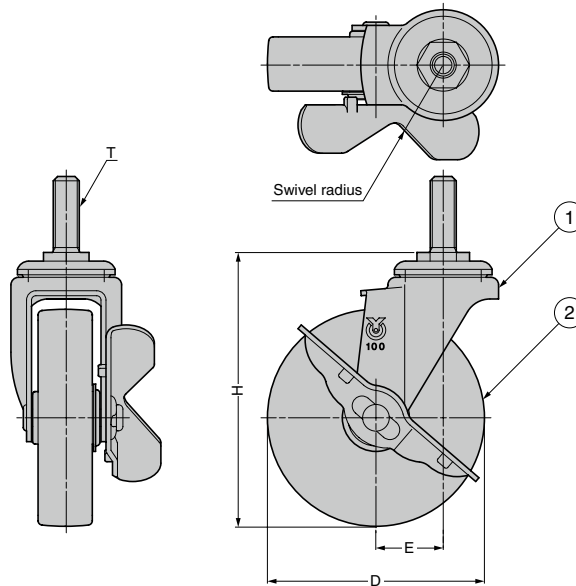

Drawing above shows the model with brake.

No.	Part Name	Material	Finish/Colour
①	Body	Stainless Steel (SUS304)	Barrel Polished
②	Wheel	Urethane Rubber (UR)	Brown + White

RoHS	CAD	Item Code	Item Name	Type	D	H	E	T	Load Capacity N/pc	Load Capacity kgf/pc	Weight (g)	Box (pcs)	Carton (pcs)
		200-130-867	SUS-ET-50UR	Without Brake	50	68	22	M12	380	38.8	175	100	-
		200-130-883	SUS-ET-65URS	With Brake	65	85	23		400	40.8	220	60	-
		200-130-870	SUS-ET-65UR	Without Brake					450	45.9	230	50	-
		200-130-886	SUS-ET-75URS	With Brake	75	95	27		450	45.9	210	60	-
		200-130-873	SUS-ET-75UR	Without Brake					470	61.2	210	60	-
		200-130-890	SUS-ET-100URS	With Brake	100	126	31		600	61.2	470	20	-
		200-130-877	SUS-ET-100UR	Without Brake					600	61.2	405	24	-

Refer to **1** **2** : P.832, **3** : P.706