

# SHOCK-ABSORBING CASTER TP Plate Type

**LOAD CAPACITY** 749.7~6272 N



TP-150LF-A-RD shown.

- Quiet movement: Elastic polyurethane wheel reduces noise during movement. (Refer to the moving noise comparison below).
- Stable movement: Excellent wheel side runout prevention, even travelling on a bad road.
- Long wheel life: Stable movement and small wheel wear ensure long service life of the wheel.
- Reduced starting force: Damping mechanism allows for easily moving a pallet carrying heavy load with a small force.

**[Choose From Six Types of Springs According to Application]**  
(Refer to item name table for details.)

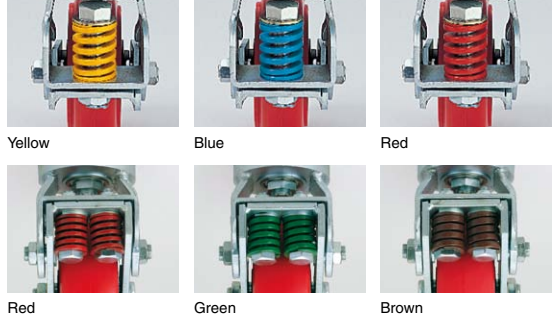

**[TP-150LF]**

**[TP-200LF]**

**[TPAH-200LF] Made to Order**

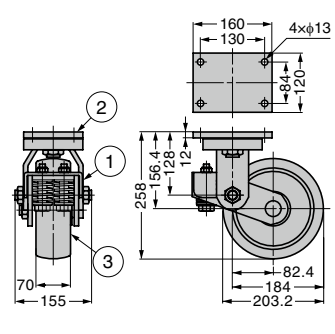
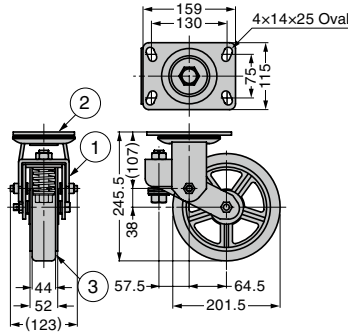
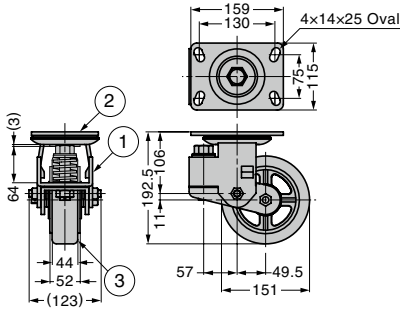

Please also refer to [Application Example] 1.

- Swivel type and non-swivel type casters are used in combination. Refer to 2 for the arrangement.

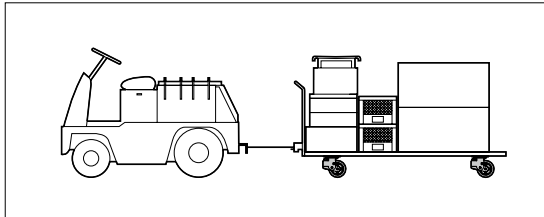

**[Moving Noise Comparison]**

	Normal Rubber Caster	Shock-Absorbing Caster (This Product)
Loaded	83dB	59dB
Unloaded	94dB	65dB

No.	Part Name	Material	Finish/Colour
①	Body	Steel	Clear Zinc Chromate
②	Plate		
③	Wheel	PUR	Red
④	Spring	Steel	Paint/See Below

The standard load of shock-absorbing caster represents the load at which the best impact absorption effect can be obtained.

RoHS	CAD	Item Code	Item Name	Wheel Dia.	Spring Colour	Load Capacity N/pc	Load Capacity kgf/pc	Standard Load N/pc	Standard Load kgf/pc	Max. Spring Compressed Length	Weight (kg)	Box (pcs)	Carton (pcs)	
-	3D	200-130-714	TP-150LF-A-YE	151	Yellow	980	100	749.7	76.5	20	5.1	4	-	
-	3D	200-130-715	TP-150LF-A-BU		Blue	2116	216	1481.7	151.2					
-	3D	200-130-716	TP-150LF-A-RD		Red	3136	320	2195.2	224					
-	3D	200-130-717	TP-200LF-A-YE	201.5	Yellow	980	100	749.7	76.5	20	6.7	2	-	
-	3D	200-130-718	TP-200LF-A-BU		Blue	2116	216	1481.7	151.2					
-	3D	200-130-719	TP-200LF-A-RD		Red	3136	320	2195.2	224					
-	3D	200-012-504	※TPAH-200LF-A-RD	203.2	Red	4900	500	3724	380	14.4	15	2	-	
-	3D	200-012-505	※TPAH-200LF-A-GN		Green	7056	720	5096	520					10.8
-	3D	200-012-506	※TPAH-200LF-A-BR		Brown	7840	800	6272	640					

Refer to 1 : P.759, 2 : P.750

※Made to order (production lead time: about 60 days).