

LEVELLING GLIDE (WITH TILT FUNCTION)

TEST METHOD 14

SG-CGP40



SG-CGP40M8L54

SG-CGP40M8L26

Features

- The body of the levelling glide can tilt up to approximately 10°, enabling it to hold level even on slanting floors.
- Separated body and base structure enables height to be adjusted by rotating the body even while a load is applied.
- The base is made from slip-resistant ethylene-vinyl acetate (EVA).

Remarks

- The base is made from slip-resistant material. Do not forcibly drag this product, as it may cause this material to wear off or peel.
- If the body cannot be rotated by hand, lift the mounted item slightly and try adjusting again.

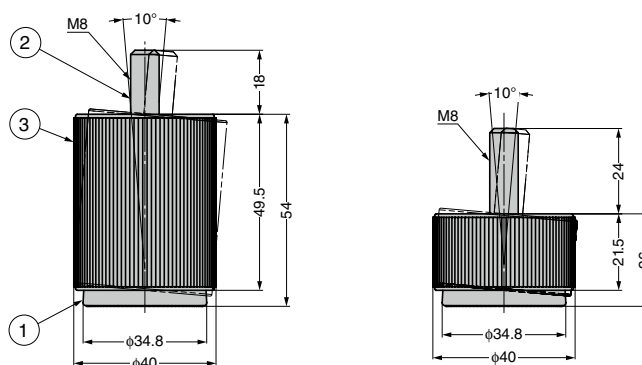

SG-CGP40M8L54

SG-CGP40M8L26

No.	Part Name	Material	Finish/Colour
①	Base	Ethylene-vinyl Acetate (EVA)	Blast Finish
②	Screw Part	Steel (SWCH)	Black Chromate Finish (Trivalent)
③	Cover	Polyamide (PA)	Black

CAD	Item Code	Item Name	Load Capacity N	Load Capacity kgf	Weight (g)
	200-042-136	SG-CGP40M8L26	588	60	38
	200-042-137	SG-CGP40M8L54			60

CASTERS & LEVELLING GLIDES

LEVELLING GLIDE (WITH TILT FUNCTION)