



HEINRICH KIPP WERK



OPERATING INSTRUCTIONS
5AXISclamping system
KIPPFlexX

Edition 20 07

- 1. Introduction and general information**
- 2. Safety and warning notices**
- 3 Description**
 - 3.1** Clamping system overview
 - 3.2** Technical explanation of the difference between positive-down force clamping and normal clamping
 - 3.3** Mounting and positioning possibilities of the baseplate
 - 3.4** Clamp construction sequence for vice / normal clamping
 - 3.5** Clamp construction sequence for positive-down force clamping
 - 3.6** Match the clamping shaft to the workpiece length
 - 3.7** Technical data
 - 3.8** Accessories
 - 3.9** Exchanging the jaw plates
- 4. Care and maintenance**
- 5. Service**

1. Introduction and general information



- Before using the KIPPFlexX 5-axis clamping system, read all of the following information in these instructions carefully.
- The basis for operating the clamping system is knowledge of the general safety instructions and safety regulations.
- The accident prevention regulations (APR) for the respective location must also be observed.
- Observe the generally applicable technical rules when handling, cleaning and using the vice and its accessories.
- The vice may only be used with original spare parts and accessories.
- All the information must be observed by all persons who work with the KIPPFlexX 5-axis clamping system.
- The clamping system is constructed according to the latest technology including all relevant safety regulations.
- The clamping system is to be used exclusively for holding workpieces that are machined on milling machines.
- This KIPPFlexX 5-axis clamping system may only be used if all safety devices of the machine are absolutely functional.
- The KIPPFlexX 5-axis clamping system can cause serious material damage if it is operated or mounted incorrectly. HEINRICH KIPP WERK GmbH & Co. KG will not in any circumstances be responsible for any type of damage caused by the operator.
- Exchange any components that are not in a perfect condition.
- If any additions or conversions are made to the 5-axis clamping system, all liabilities and quality feature guarantees expire.
- Basically, the General Terms of Sale, Delivery and Payment of HEINRICH KIPP WERK GMBH & CO. KG apply.



Attention: The following points must be observed!

- Do not exceed the permissible tractive force of 60 kN (at 140 Nm).
 - The maximum clamping travel of 1 mm per jaw must not be exceeded at the downthrust clamping.
 - Check that everything is correctly and securely mounted before any milling work.
 - Check that all the screw connections are completely tightened to the correct torque.
 - The clamped workpiece may only have a maximum parallel displacement of 0.5 mm along the entire clamping width.
-
- 0.2 pin with \varnothing 6 mm cup point; universal pin for positive clamping without pre-embossing (e.g. machining blanks).



- The spindle nut may not be moved beyond the marking (V-notch) on the shaft. This ensures that a sufficient number of threads is always used.

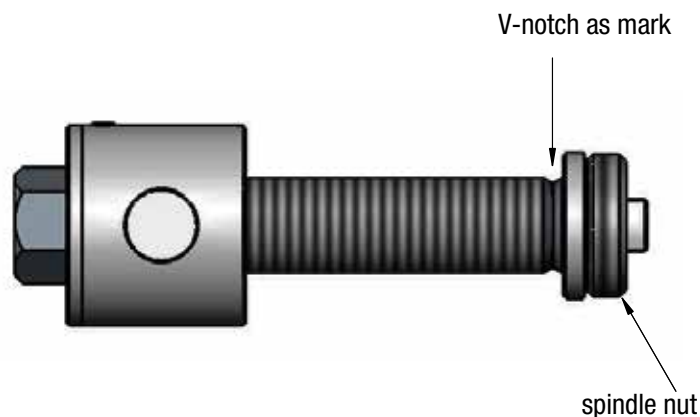

- The union nut must contact the face of the extension shaft before assembly.
- When assembled, the distance between the union nut and the extension shaft may not exceed max. 10 mm in order to avoid damage to the thread.

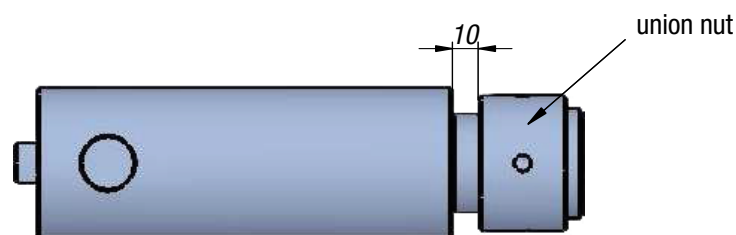

3. DESCRIPTION

The KIPPflexX 5-axis clamping system is characterised by high stability, flexibility and user-friendliness. This 5-axis clamping system can be used as a positive-down force vice or as a normal vice for holding e.g. blanks. The user can decide if positive-down force is desired or not when operating the clamping unit.

- If both jaw units are locked, positive-down force is effected.
- If one jaw unit remains unlocked, this jaw can be moved and clamps using the normal vice principle.
(see 3.2 Technical explanation of the difference between positive-down force clamping and normal clamping)

When using the positive-down function, the workpiece is pulled down onto the rest with a repeat accuracy of ± 0.01 mm. A workpiece clamping height of 180 mm enables very good accessibility with short tools when machining.

The clamping width is infinitely adjustable using a hand crank, thus reducing set-up times. Clamping is done using a torque wrench with max. 140 Nm, which results in an enormous clamping force of 60 kN directly in the spindle under the workpiece.

In addition, the closed geometries and the associated imperviousness to dirt reduce maintenance and service time to a minimum.

3.1 Clamping system overview

KIPPflexX 5-axis clamping system (package contents)

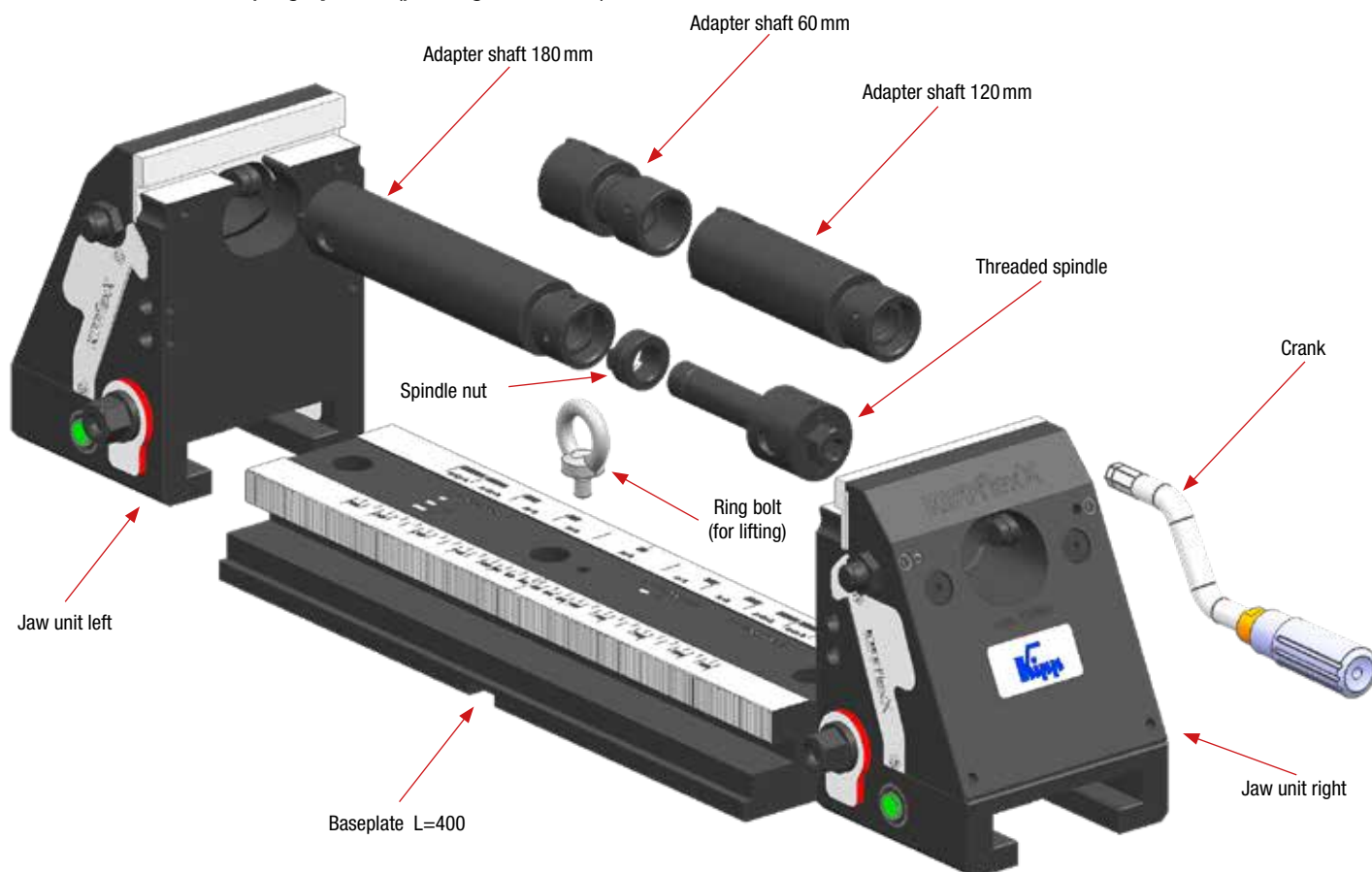

3. DESCRIPTION

3.2 Technical explanation of the difference between positive-down force clamping and normal clamping

Blank clamping / Vice principle

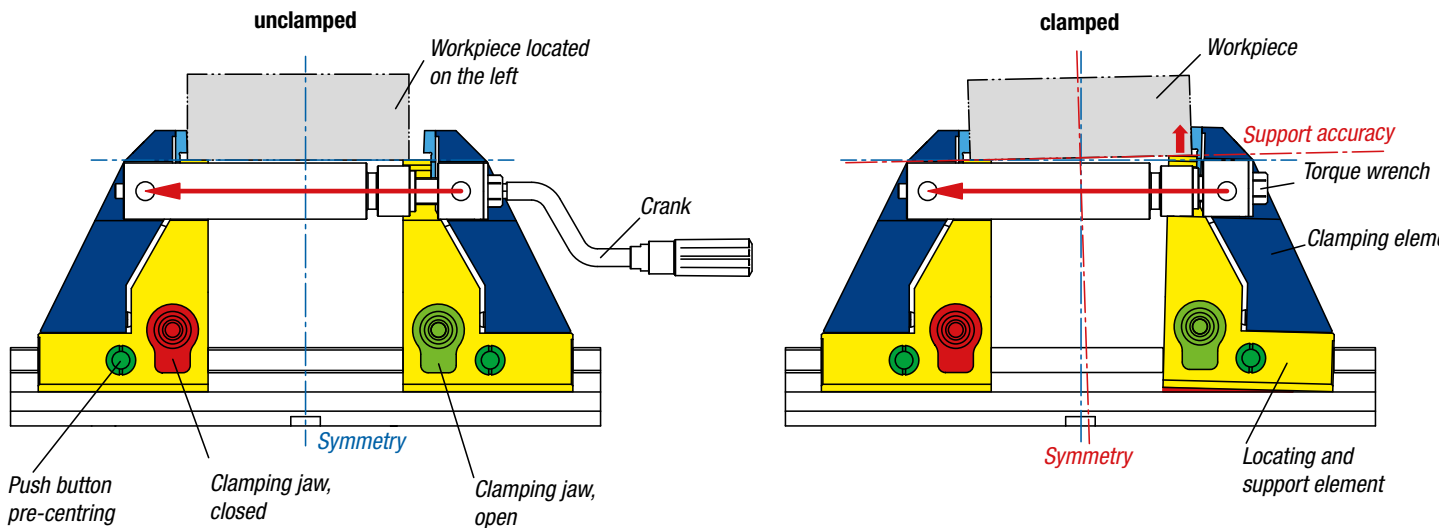

Downthrust clamping

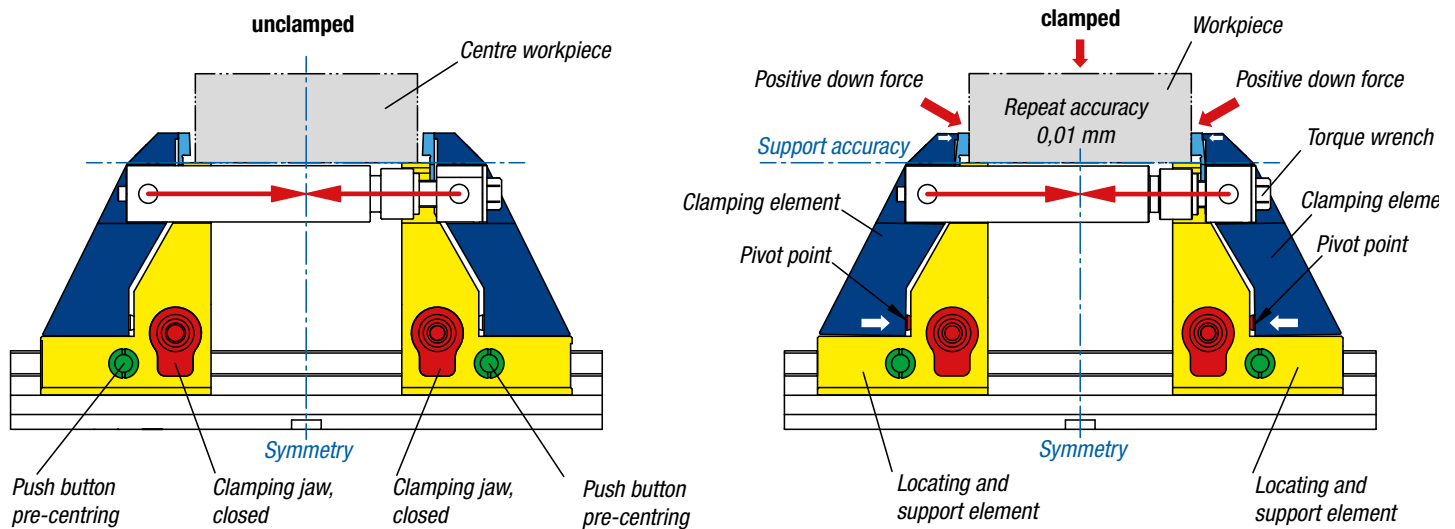

3. DESCRIPTION

3.3 Mounting and positioning possibilities of the baseplate

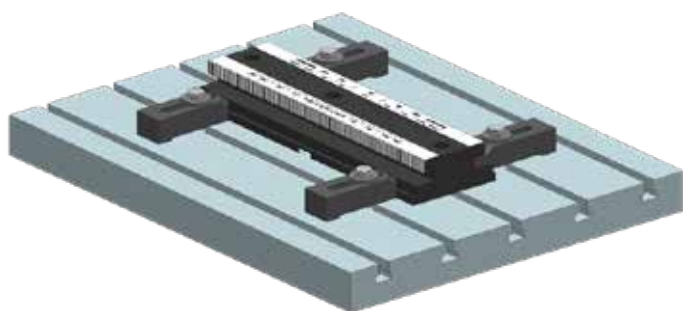

Baseplate on a T-slot machine table

→ using clamping claw sets

Positioning and fastening with clamping claw set **K1008** which is available as standard for M12 or M16

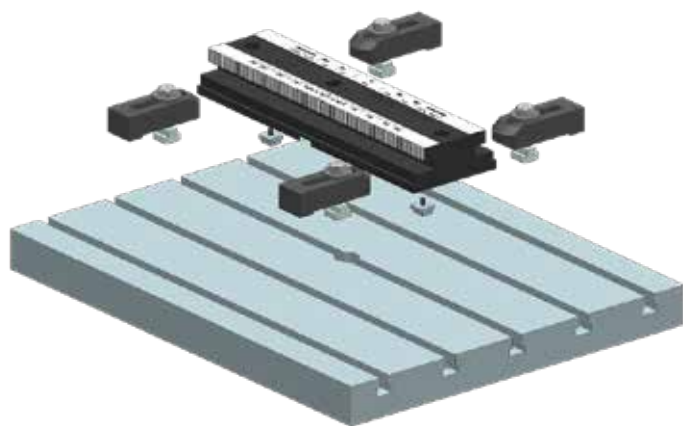

Clamping claw set **K1008** consisting of:

- 4x claw clamps (M12 or M16)
- 4x T-slot nuts (M12 or M16)
- 4x cap screws (M12 or M16)
- 4x washers (M12 or M16)

Optional:

- 2x slot guide keys for 14 mm or 18 mm T-slots
- 2x M6x12 fastening screws for slot guide keys

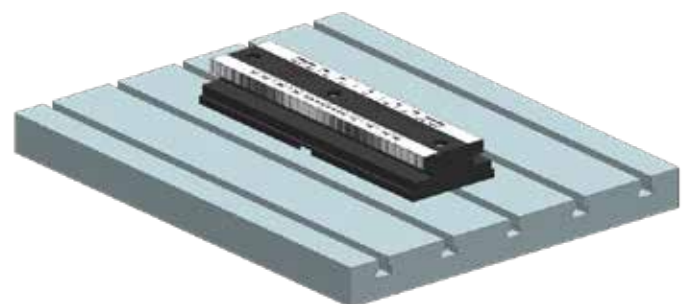

Baseplate on a T-slot machine table

→ 3x M12x65 cap screws through the baseplate

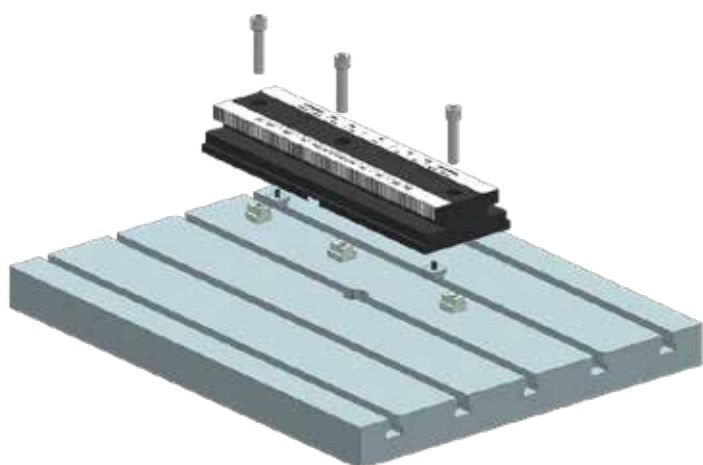

Positioning and fastening with:

- 2x 14/18 mm slot guide keys
- 2x M6x12 fastening screws for slot guide keys
- 3x M12x65 cap screws
- 3x 14 or 18 mm T-slot nuts

3. DESCRIPTION

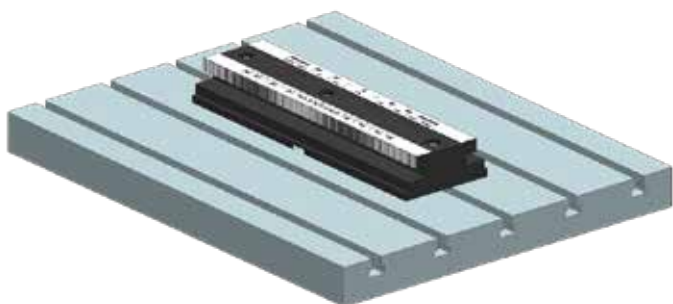

Baseplate on a T-slot machine table with central hole

→ over a central bolt + 1x slot guide key

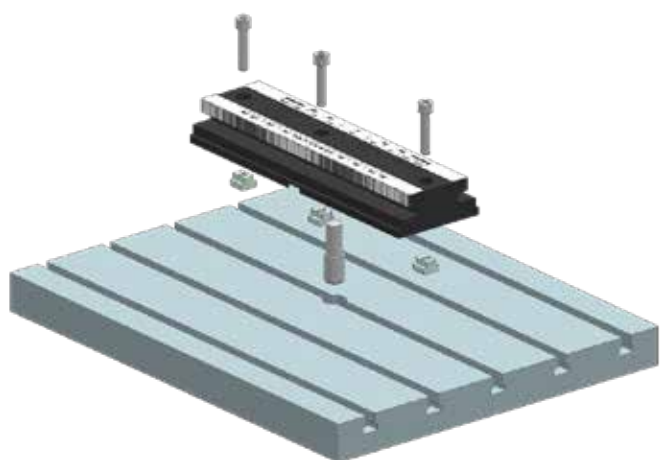

Positioning and fastening with:

1x central bolt

(customer specific depending on the central bore in the machine table
Ø20 H7 with a depth of 10 mm in the baseplate)

1x 14/18 mm slot guide key

1x M6x12 fastening screw for slot guide key

3x M12x65 cap screws

3x 14 or 18 mm T-slot nuts

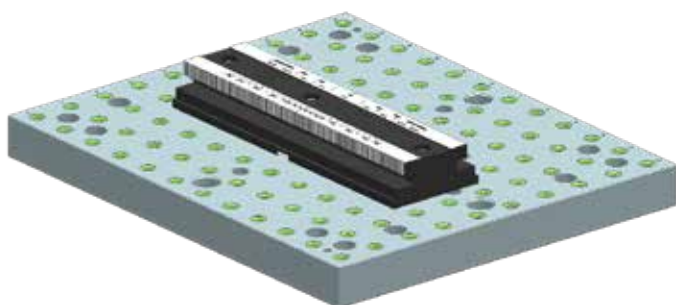

Baseplate on a grid plate

Positioning and fastening with:

2x M12x65 shoulder screws with f7 shaft (ends)

1x M12x65 cap screw (middle)

There are 3 reamed holes for available for a 50 mm grid.

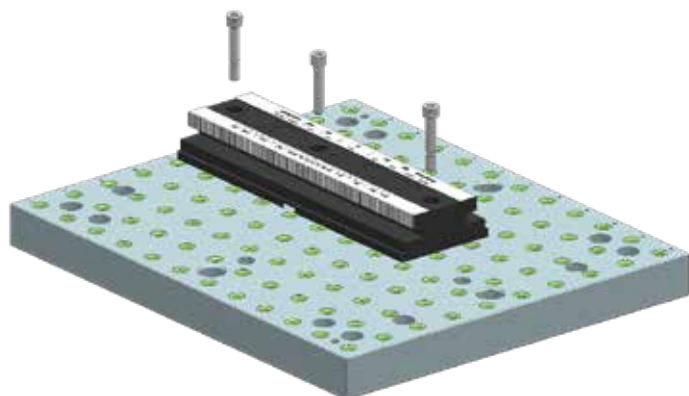

3. DESCRIPTION



Baseplate on a zero-point clamping system

1x clamping pin form A
for 25 H7 bores, collar height 5 mm,
for M12 cap screw (centring pin)

1x clamping pin form B
for 25 H7 bores, collar height 5 mm,
for M12 cap screw (compensating / bayonet pin)

The clamping pins are screwed into the baseplate using M12 screws.
The centring in the baseplate takes place via 2x 25H7 bores, whereby
the clamping pins are positioned with repeat accuracy.

Bottom view of the baseplate with mounted zero point clamping pins.

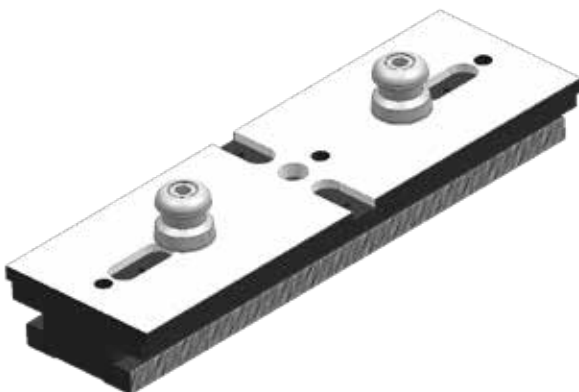
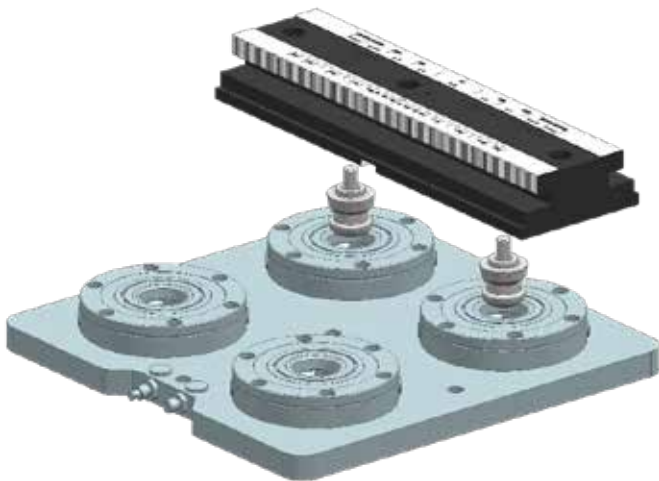
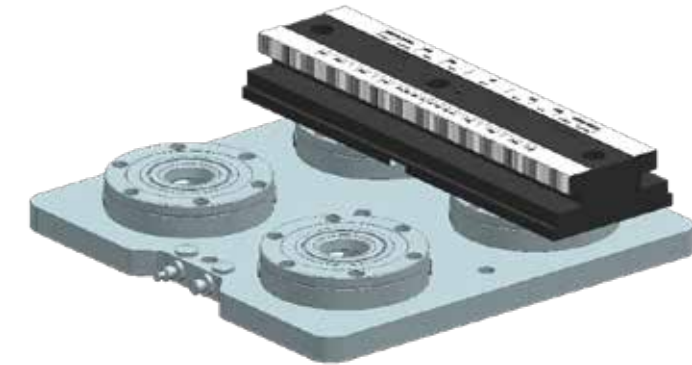

3. DESCRIPTION

3.4 Clamp construction sequence for vice/normal clamping

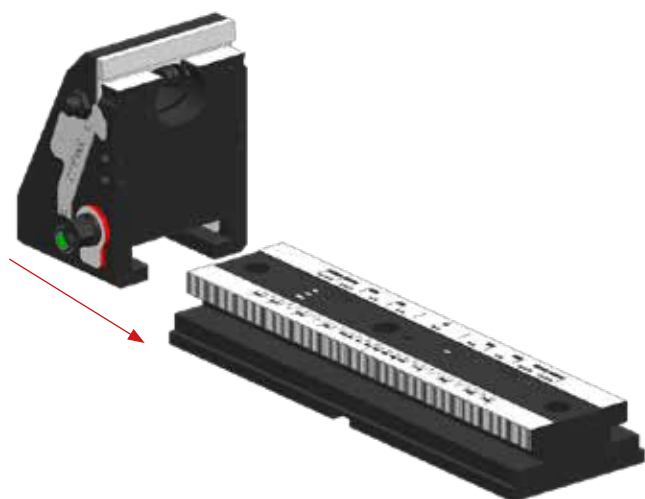

Slide the left jaw unit with clamping elements open onto the baseplate to the desired position.

Ensure that the clamping elements do not protrude into the T-slot of the jaw unit, otherwise they may jam in the baseplate when pushed on.

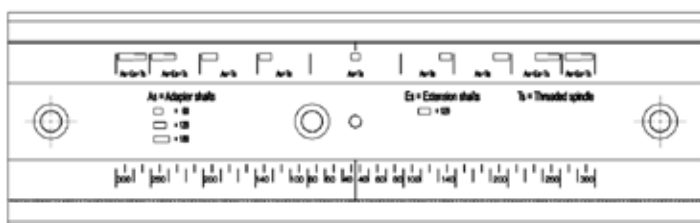

The desired workpiece size and required adapter shafts can be read off using the symbols and scale and set on the base plate.

This enables a quick pre-positioning of the jaw unit in the desired clamping range.

3. DESCRIPTION

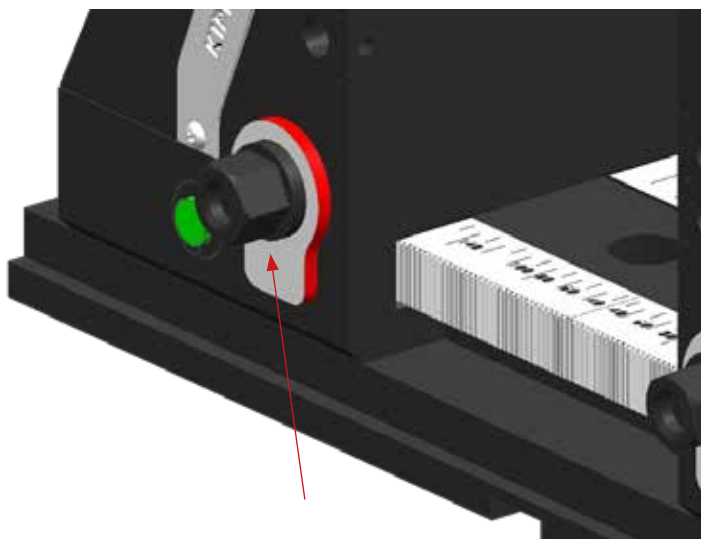

A red mark is visible on the periphery when the clamping element is open. This should be at least 2 mm clear.

Once the clamping element is later tightened, no red marking should be visible.

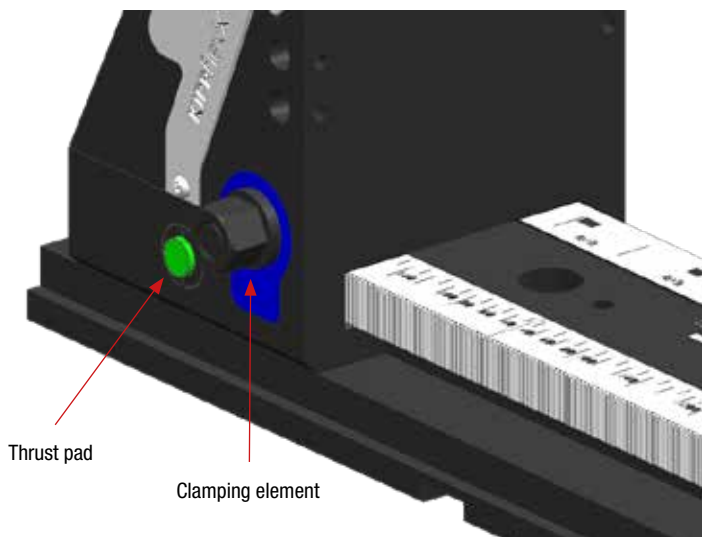

Pre-centre the jaw unit via thrust pins (shown in green) by pushing into the tothing.

Now tighten the nut on the clamping element (shown in blue) using a torque wrench set to min. 50 Nm / max.100Nm until the red marking is no longer visible.

The jaw unit is now completely positively engaged with the baseplate through the tothing.

3. DESCRIPTION

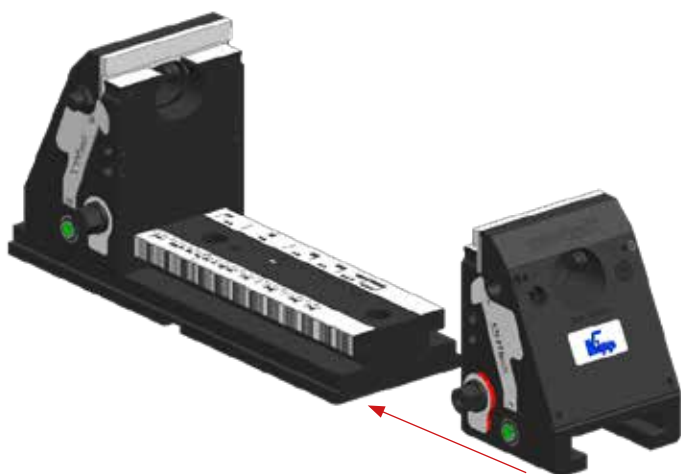

The left jaw unit is now firmly fastened to the baseplate.

Slide the right jaw unit with clamping elements open onto the baseplate.



Pre-set the threaded spindle with the corresponding adapter shaft on the movable locking pin (shown in brown) before mounting on the vice.

The clamping shaft is later hung onto the fixed locking pin (shown in pink).



By presetting with the locking pins, a quick assembly of the threaded spindle incl. adapter shaft is achieved.

3. DESCRIPTION

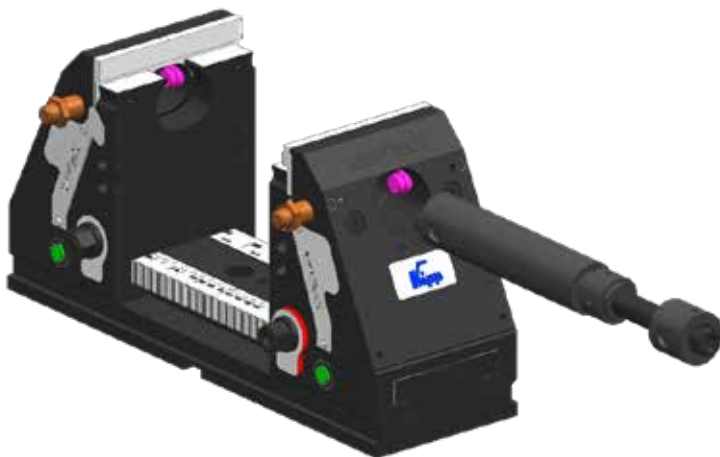

Insert threaded spindle with corresponding adapter shaft. This can be done from both sides.

Then insert into the fixed locking pin (shown in pink) at the back.

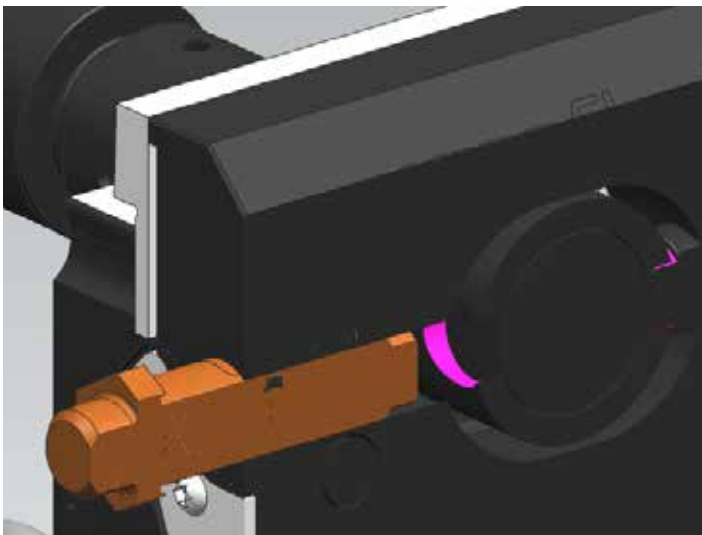

Secure the locking pin (shown in brown) by turning it clockwise into the hole (pink) of the threaded spindle and adapter shaft.

3. DESCRIPTION



The force-transmitting spindle is now secured in the KIPPflexX via the locking pins.

This type of mounting enables the KIPPflexX 5-axis clamping system to be used as a normal vice.



Use the crank handle to move the right-hand jaw unit to the appropriate clamping width.

The jaw unit can be infinitely adjusted through 60 mm via the threaded spindle.

The torque wrench **K1489.01** is recommended for tightening.

3. DESCRIPTION

3.5 Clamp construction sequence - positive-down force clamping

Follow all the previous steps carried out for the normal vice version

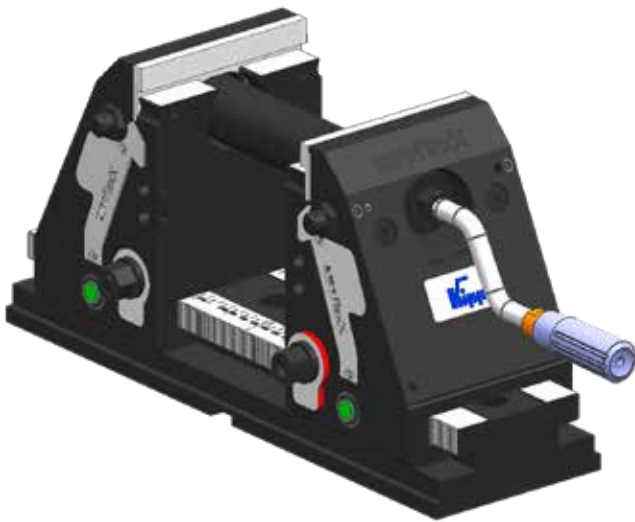

When using the KIPPflexX as a positive-down vice, the following must then be observed

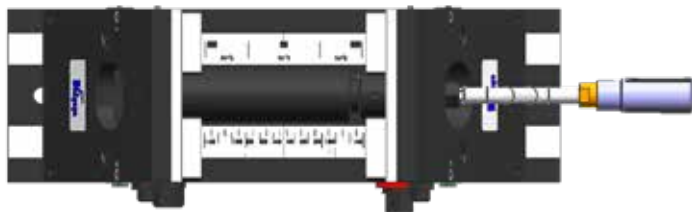

Preset the KIPPflexX 5-axis clamping system using the crank handle

Example:
A workpiece is 145 mm long

To create a pull-down effect, a maximum of 2 mm must be added to the actual workpiece length (here max. 147 mm)

3. DESCRIPTION



Lay the workpiece in and position it against the fixed jaw unit (here left).

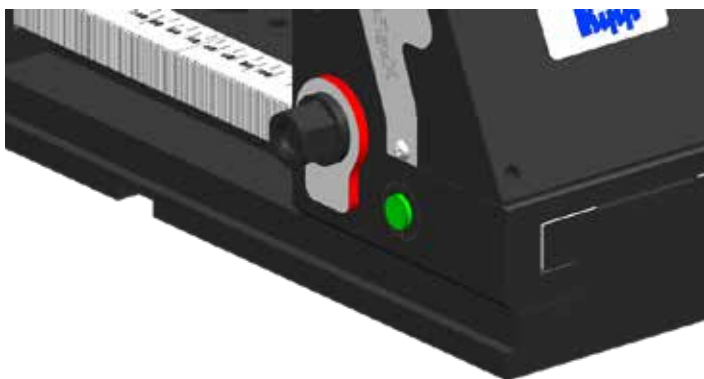

Pre-centre the jaw unit via thrust pins (green) in the toothing. Then tighten the nut of the clamping element (blue). (min 50 Nm - max. 100 Nm)

3. DESCRIPTION

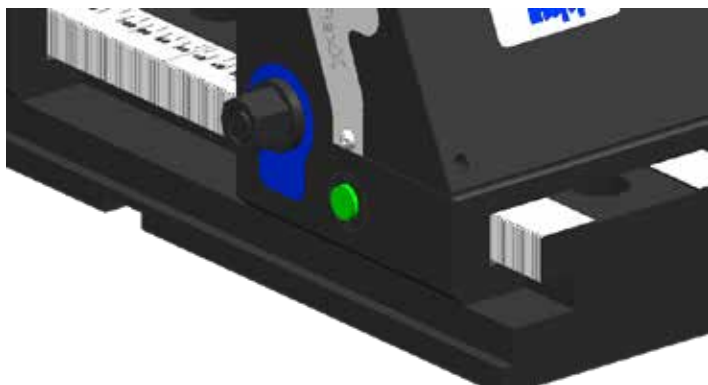

The red mark on both clamping elements is no longer visible and produces a form fit on the baseplate with the tothing.



This type of mounting enables the KIPPflexX 5-axis clamping system to be used as a positive-down force vice.

The KIPP torque wrench **K1489.01** is recommended for tightening.

3. DESCRIPTION

3.6 Match the clamping shaft to the workpiece length

Clamping width overview

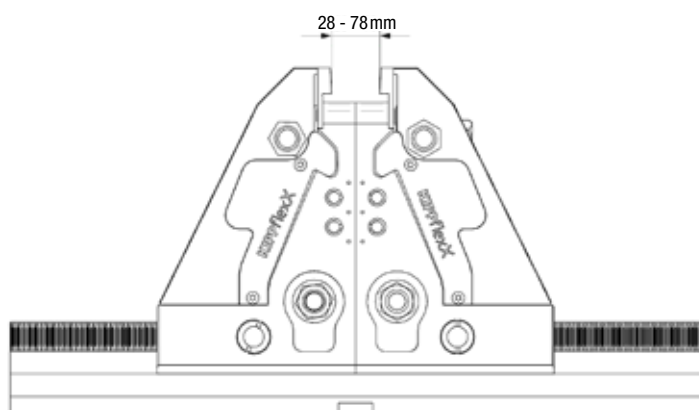

Clamping width 28 – 78 mm

Adapter shaft 60 mm + Threaded spindle

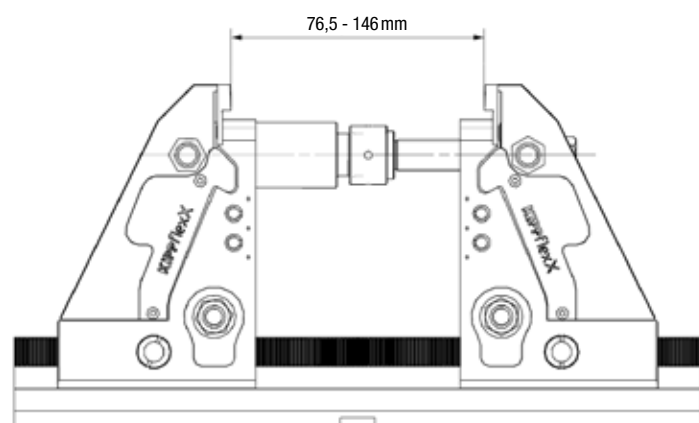

Clamping width 76,5 – 146 mm

Adapter shaft 120 mm + Threaded spindle

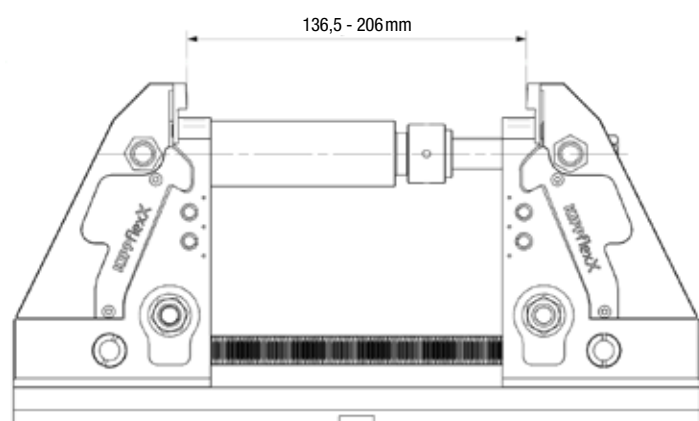

Clamping width 136,5 – 206 mm

Adapter shaft 180 mm + Threaded spindle



3. DESCRIPTION

3.6 Match the clamping shaft to the workpiece length

For wider clamping widths (beyond the crank range) the 120 mm extension shaft (accessory) can be added.

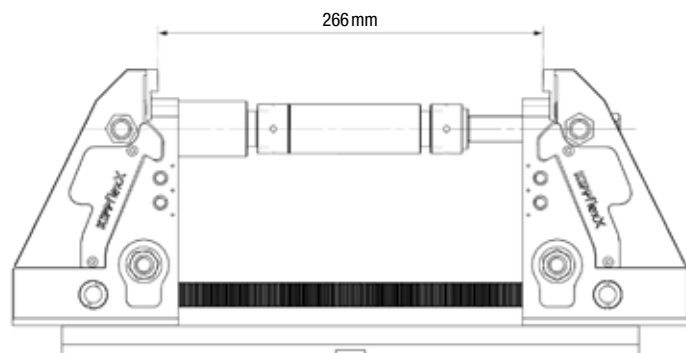

Clamping width up to 266 mm

Adapter shaft 120 mm + Extension shaft 120 mm + Threaded spindle

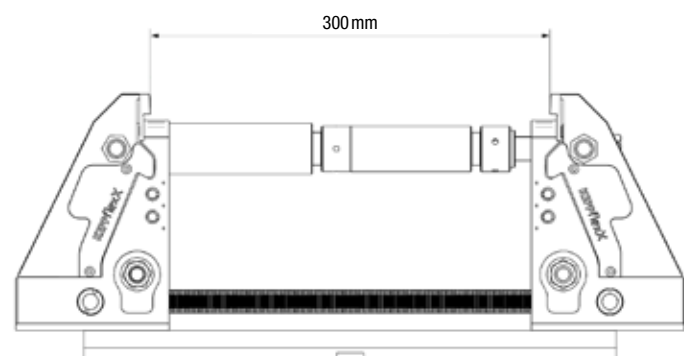

Clamping width up to 300 mm

Adapter shaft 180 mm + Extension shaft 120 mm + Threaded spindle

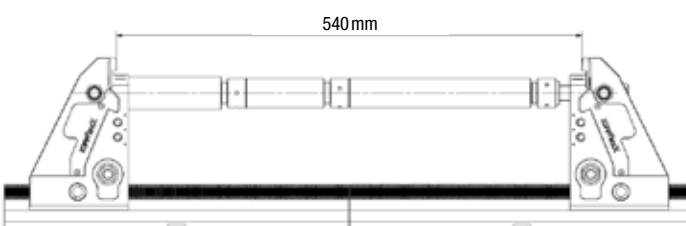

Clamping width up to 540 mm

Additional baseplate L=400 mm + Adapter shaft 180 mm +
Extension shaft 120 mm +
Extension shaft 240 mm + Threaded spindle

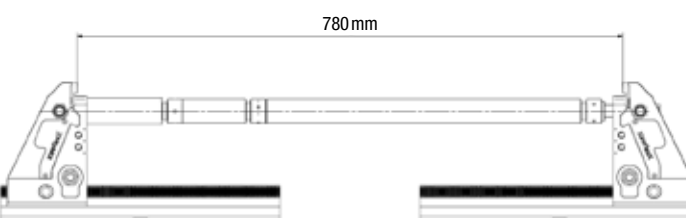

Clamping width up to 780 mm

Additional baseplate L=400 mm + Adapter shaft 180 mm +
Extension shaft 120 mm +
Extension shaft 480 mm + Threaded spindle



An infinite clamping range is achieved using a combination of 60, 120, 240, 480 mm extension shafts.

3. DESCRIPTION



3.7 Technical data

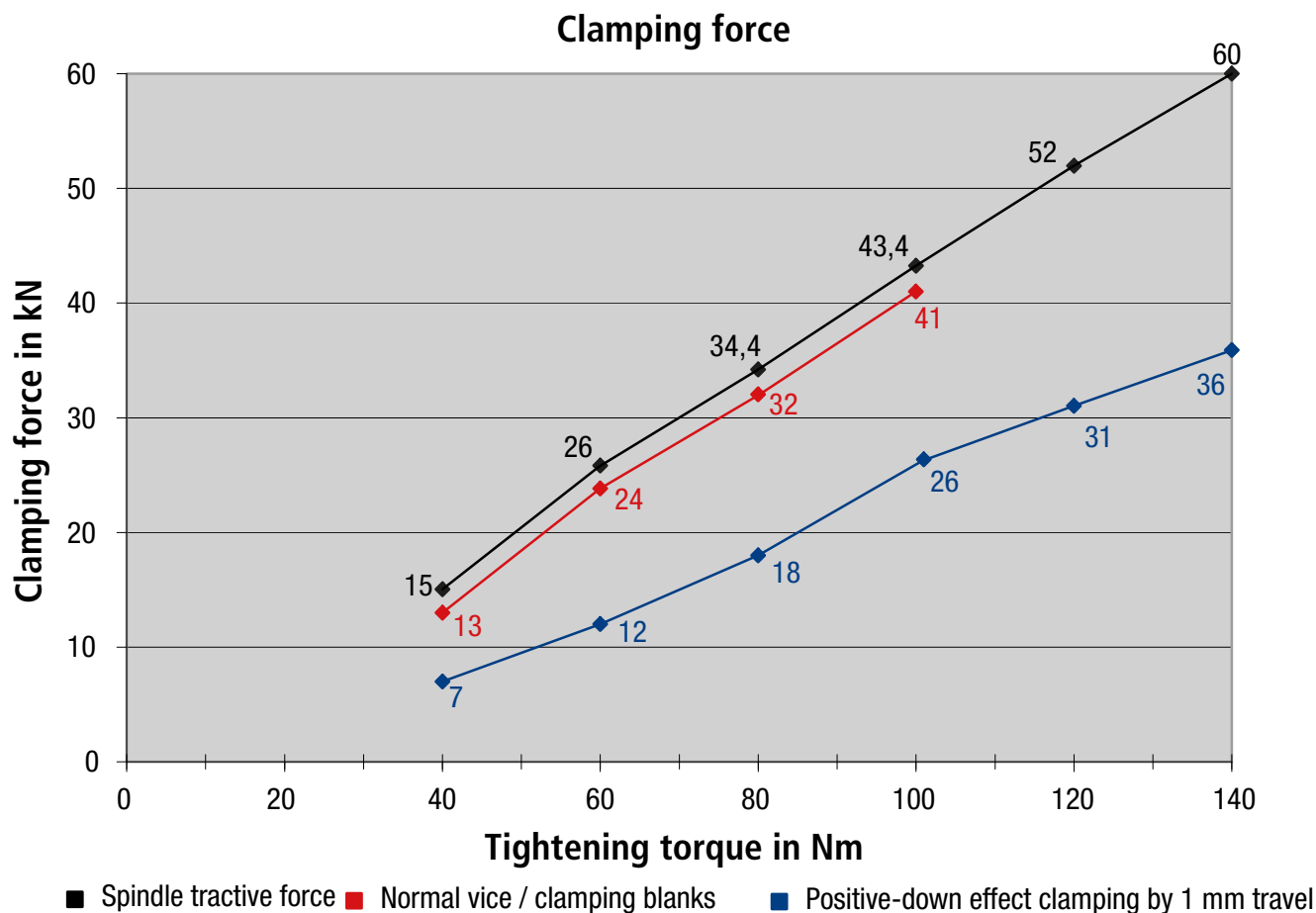

* When clamping blanks the highest value of 41kN was achieved with 100Nm.

* with <2mm clamping travel the force is greater.

for maximum force with the positive-down function a tightening force of 140Nm can be used.

General information:

The values shown for the normal vice and positive-down effect refer to the force applied directly to the workpiece.

- Clamping height over machine table 180 mm (without optional seating ledge)
- Clamping width 28 - 206 mm (for cranking range on baseplate L=400)
up to 300 mm (for positive-down clamping on baseplate L=400)
- Clamping force acc. to diagram
- Jaw width 125 mm
- Weight 40 kg
- Baseplate length 400 mm (standard equipment)
other lengths on request for clamping range > 300 mm

3. DESCRIPTION

3.8 Accessories

In addition to the equipment supplied, other articles suitable for the KIPPflexX 5-axis clamping system are available as accessories. You can find the details in the catalogue or online on our homepage

- Jaw plates smooth **K1557.1250** (supplied singly)



- Jaw plates with pins **K1557.1251** (supplied singly)



- Seating ledges **K0974.1250312, K0974.1250317** (supplied in pairs)
Available in H = 12 mm, 17 mm



- Seating ledges screw-on **K0974.1250515** to mill to size
(supplied in pairs)



- Jaw plates machinable **K0975.1252**
(supplied singly)



- Extension shafts **K0990** L=120, 240, 480 mm
(required for clamping ranges over 206 mm)



- Cylinder clamping set **K0989.12535** (supplied in pairs)



3. DESCRIPTION

3.8 Accessories

Stop set K0993.150

The stop can be mounted either fixed or to swivel.

This stop can be swung down to allow machining on the workpiece stop face. It engages with a spring plunger. It can be mounted on both sides and facing front or back.



- Mount the stop as shown in the illustration. Make sure that only the ball of the spring plunger (13) is projecting from the back of the stop arm (10)!
- When required, only tighten the screw (11) so much so that the stop can still swivel. Secure the screw (11) against loosening with the grub screw (14). The spring washer (15) exerts pressure on the stop. The centring ring (12) guides the stop.
- Slide the stop pin (15) into position and clamp with the cap screw (16).

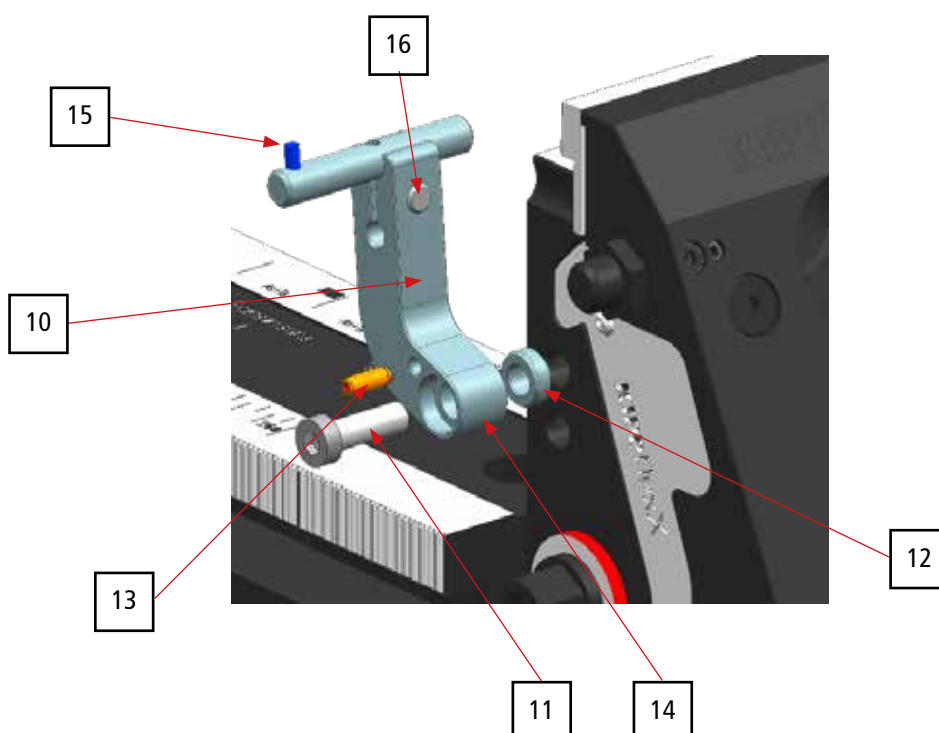

10	Body stop
11	DIN 6912 screw 8x30 10.9
12	Centring ring
13	Spring plunger
14	Spring washer
15	Stop pin incl. dowel pin
16	DIN 6912 cap screw 8x16 10.9

3. DESCRIPTION

3.9 Exchanging the jaw plates

To exchange the jaw plates (18, smooth or with holes for pins) or for a thorough cleaning, the jaws must be separated.

Proceed as follows:

- Remove the 2 screws (19), ensuring that the 2 O-rings (20) are not damaged or misplaced
- Remove „rear“ clamping element (21) from the jaw by lifting diagonally upwards
- Screw out the 2 M6x10 Torx screws
- Exchange the jaw plate (18)
- To re-assemble, follow the previous instructions in reverse. Only tighten the screw (19) hand tight.

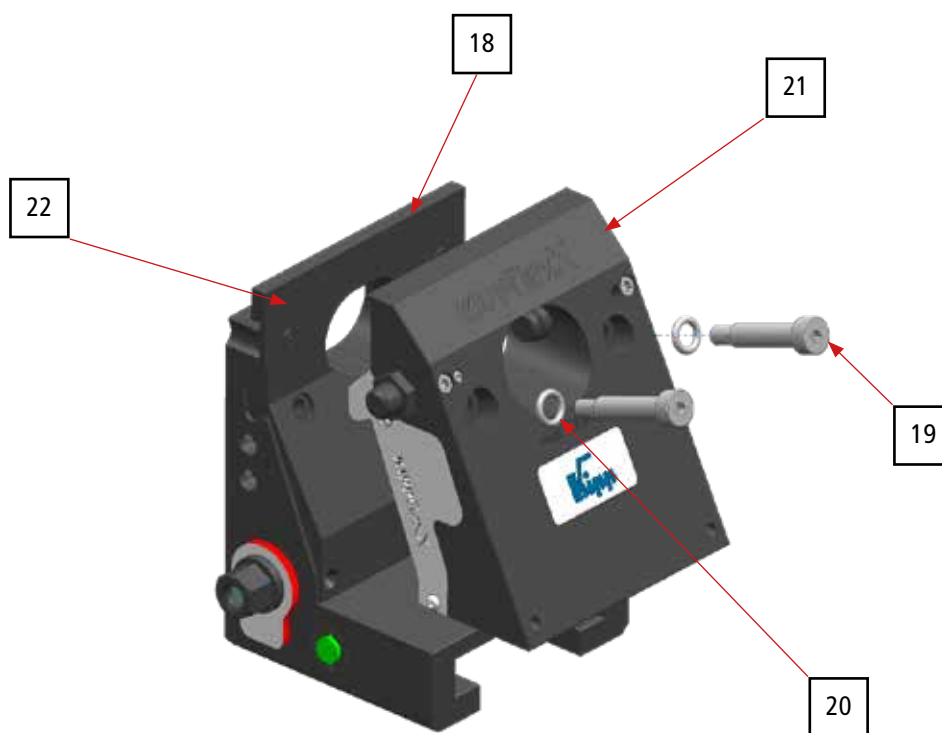

18	Jaw plate
19	Shoulder screws similar to DIN ISO 7379, M10x40
20	O-ring Ø 10x3
21	Clamping element „rear“
22	Torx screws M6x10

4 . C A R E a n d M A I N T E N A N C E



Clean the vice regularly from accumulated swarf and dirt. The traction spindle must be lightly oiled repeatedly during purely dry machining. Make sure that all threads are clean and not damaged.

After cleaning and when not in use for a long period, oil all parts lightly to prevent corrosion. To reach the space between the jaw components, please note point 3.9 on dismantling the parts.

5 . S E R V I C E

HEINRICH KIPP WERK GmbH & Co. KG

Heubergstrasse 2

72172 Sulz am Neckar, Germany

Tel. +49 7454 793-0

Fax +49 7454 793-7983

info@kipp.com

www.kipp.com

Reproduction, transfer, distribution or saving of part or all of the contents in this document in any form without the prior written permission of HEINRICH KIPP WERK GmbH & Co. KG is prohibited.

HEINRICH KIPP WERK GmbH & Co. KG continuously develops its products in compliance with its own policy. HEINRICH KIPP WERK GmbH & Co. KG reserves the right to make changes and improvements to any of the products described in this document without prior notice.

HEINRICH KIPP WERK GmbH & Co. KG is not under any circumstances responsible for any type of special, incidental, direct or indirect damage regardless of how this damage is caused.

The content of this document is presented in its current version. HEINRICH KIPP WERK GmbH & Co. KG does not provide any guarantee, either explicit or tacit, of the correctness or completeness of the content of this document, including, but not limited to, implied warranties regarding its marketability or fitness for a particular purpose, unless the applicable legislation or jurisdiction makes such liability mandatory. HEINRICH KIPP WERK GmbH & Co. KG reserves the right to make changes to this document or withdraw it at any time without prior notice.

WE01ENBA5K2007

HEINRICH KIPP WERK GmbH & Co. KG

Heubergstraße 2
72172 Sulz am Neckar

Tel. +49 7454 793-7652
Fax +49 7454 793-7983

spanntechnik@kipp.com
www.kipp.com

Status: 01.07.2020