

JGG Series

Load rating 1000kg

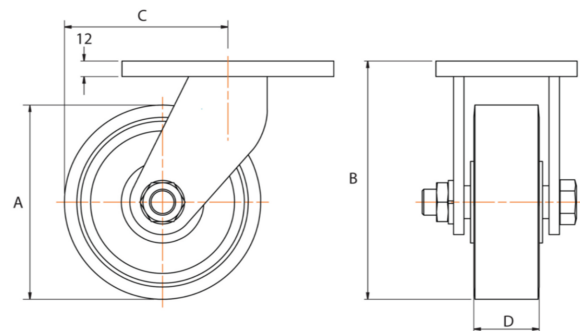
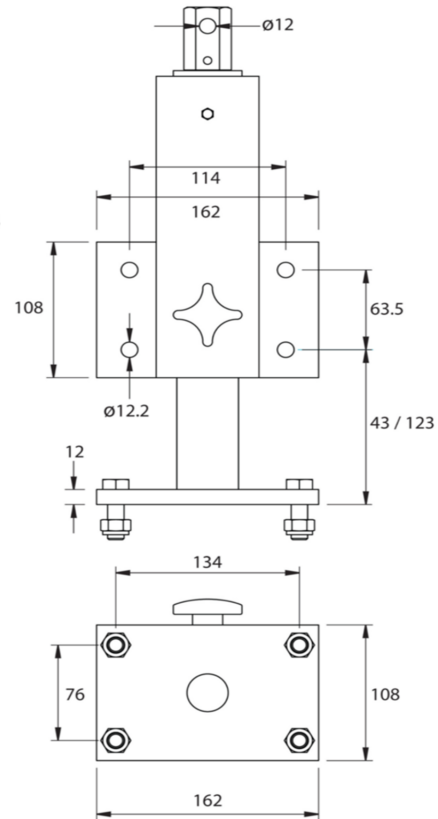
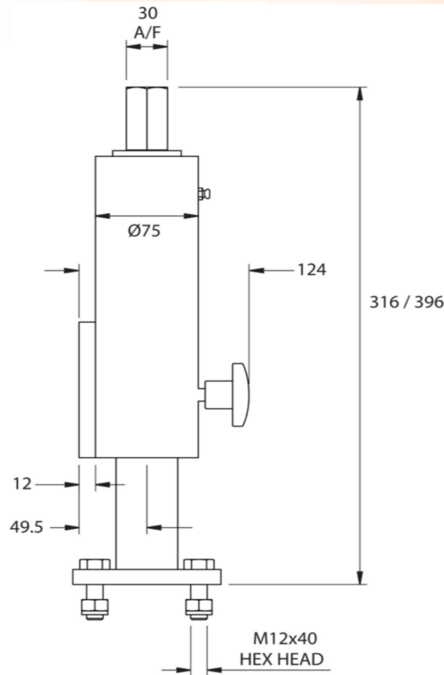

Brauer have developed a range of jacking units expanding further our comprehensive range of heavy duty castors and wheels. The jacking units are highly adaptable across a broad range of environments and applications. Many options are available giving this new product unsurpassed flexibility for the worldwide market place. Availability and delivery is enhanced due to products being totally manufactured within the wheels and castors division based in the UK. Robust design. Load rating up to 1000kg per unit. Integral swivel mechanism incorporated into jacking castor. Designed to suit our GG fixed castor. Wheel options from 100mm to 250mm diameter. Wheel options include steel, polyurethane and nylon. Jacking units now form part of Brauer comprehensive range of wheels and castors.

Approximate weight: 25Kg

FOR TECHNICAL INFORMATION COVERING LOAD FACTORS, ETC., SEE 'DESIGN DATA' INDEX ON PAGE 20

A	B	C	D				
Wheel Diameter	Overall Height	Swivel Radius	Tread Width	Max Load Rating	Wheel Bearing Type	PART NUMBER	Approx Weight kg
POLYURETHANE TYRED WHEEL							
100	133	90	40	450	Ball Journal	JGG/H100/40BJ	33
150	184	125	50	900	Ball Journal	JGG/H150/50BJ	34
200	235	160	40	900	Ball Journal	JGG/H200/40BJ	36
250	286	195	45	1000	Ball Journal	JGG/H250/45BJ	41
JACKING UNIT ONLY						JU1000	25

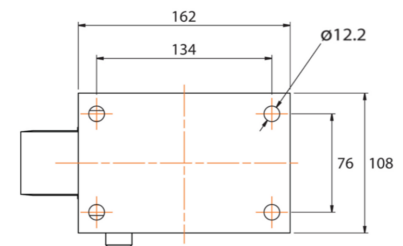

NOTE: Also available with other wheel types.

1000KG JACKING UNIT