

MONITOR ARM KA-TLG Tilt Angle Adjustment by Button



- The tilt angle can be adjusted in 10° increments while the button is pressed.
- The back lever allows for height adjustment in 25 mm increments. It has a friction mechanism which prevents against accidental release.
- The monitor-mounting holes are compliant with the VESA standard. (75 x 75 mm, 100 x 100mm)
- Available monitor size: 12 - 22.9 inches (Weight: Max. 10 kg)

[Remarks]

- Please support the monitor with a hand when adjusting the angle and height.

[Tilt and Height Adjustments]

● KA-TLG2-100 (Dual axis)

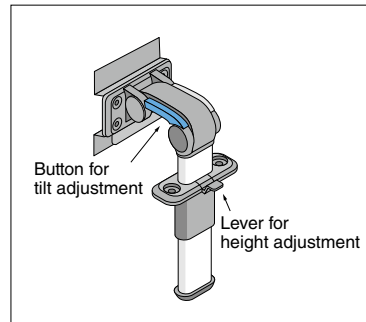

The tilt adjustment of both axes unlocks while the button is pushed.

● KA-TLG1-100 (Single axis)

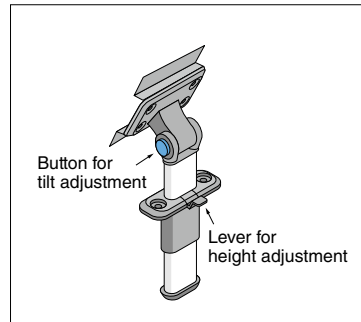

The tilt adjustment unlocks while the button is pushed.

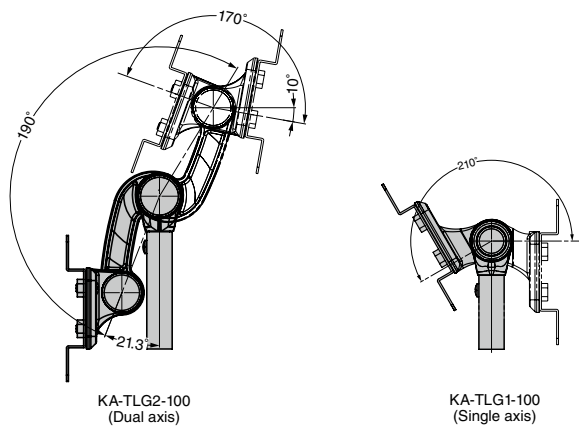
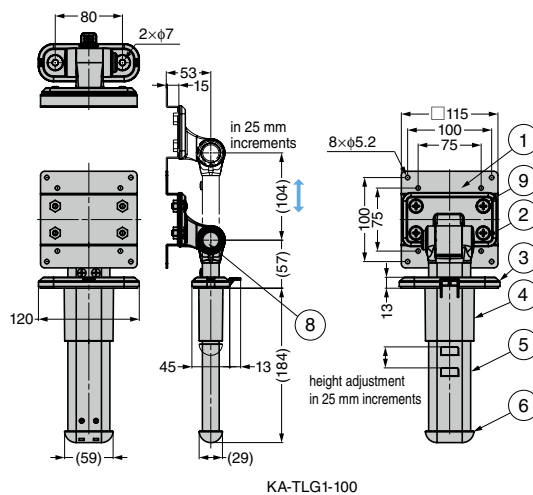
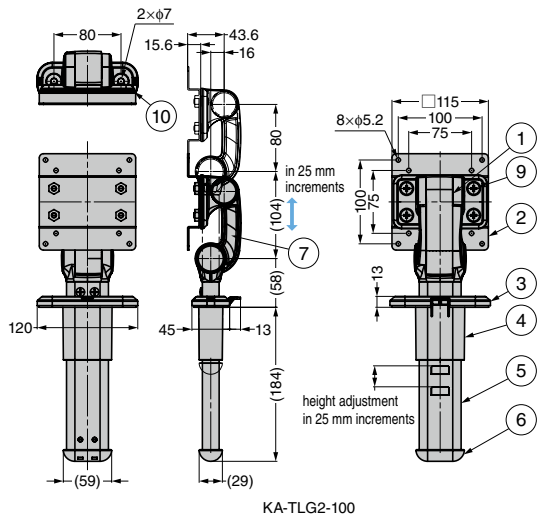

[Cut Out Dimensions]

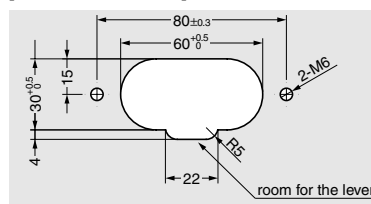

No.	Part Name	Material	Finish/Colour
①	Bracket	Polyamide (PA)	Black
②	Mounting Plate	Steel (SPHC)	
③	Cover	Polycarbonate	
④	Outer Pipe	ABS	Anodized
⑤	Aluminium Pipe	Aluminium Alloy	
⑥	End Cap	ABS	Black
⑦	Button	Polyamide (PA)	Grey
⑧	Button	ABS	
⑨	Cross-recessed trus head screw	Steel	Black Chromate
⑩	Packing	Nitrile Rubber (NBR)	Black

RoHS	CAD	Item Code	Item Name	Axis	Vertical Load Capacity		Allowable Moment		Weight (g)	Box (pc)
					N	kgf	N.m	kgf.cm		
		210-044-071	KA-TLG2-100	Dual	100	10.2	15	153	705	1
		210-044-070	KA-TLG1-100	Single					545	1