

Supporti Inox a soffietto

Caratteristiche: **ALLUNGABILE**

Features: **EXTENDABLE**

ACCESSORI

Martin
Levelling Components

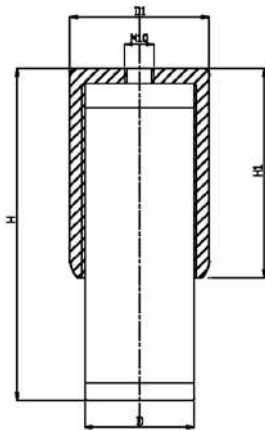

CODICE - CODE	DIMENSIONI PRINCIPALI - MAIN DIMENSIONS					CARICO STATICO STATIC LOAD NEWTON
	D	D1	H	H1	F	
50039	44,5	52	85/110	62	M10	4000
50040	44,5	56,5	130/180	85	M10	5000
50050	56,6	64	130/180	85	M10	8000

• Manicotto acciaio inox (AISI 304) con filettatura interna in nylon rinforzato con fibre di vetro. Piede in acciaio inox AISI 304 a base rotonda. Disco antiscivolo in PVC nero

• *Stainless steel reducing socket 1.4301 with internal thread in nylon reinforced by fiber glass. Stainless steel foot 1.4301 Anti-slip pad in black PVC*

ACCESSORI

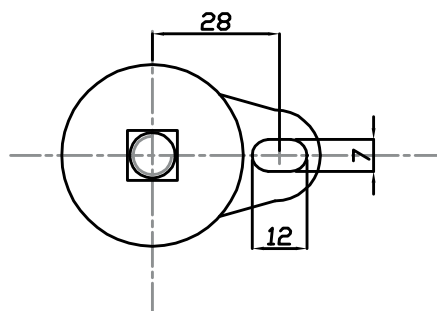
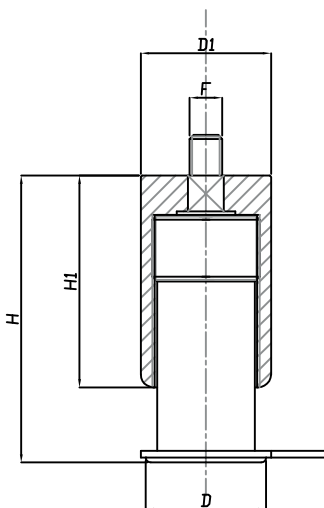

CODICE CODE	DESCRIZIONE DESCRIPTION	DIMENSIONI PRINCIPALI - MAIN DIMENSIONS					CARICO STATICO STATIC LOAD NEWTON
		D	D1	H	H1	F	
50019/F	SUPPORTO INOX CON FISSAGGIO	40	40	88/110	67	M10x12	3000

• Supporto in acciaio inox (AISI 304), tappo in poliammide rinforzata, stelo in acciaio inox AISI 304

• *Material: stainless steel support 1.4301, plug in polyamide reinforced by fiber glass, stainless steel screw 1.4301*