

Piede Inox

VULCANIZZATO

Caratteristiche: BASE VULCANIZZATA Ø 80 CON DOPPIO FISSAGGIO,
STELO SNODATO 10°

Features: VULCANIZED BOLT/DOWN BASE Ø 80, 10° ARTICULATED STEM

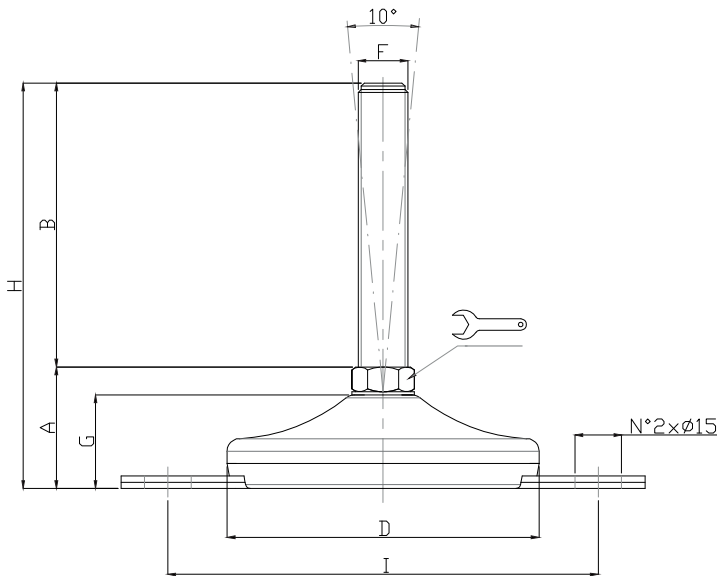

CODICE - CODE	descrizione description	DIMENSIONI PRINCIPALI - MAIN DIMENSIONS								CARICO STATICO STATIC LOAD NEWTON
		A	B	D	CH	F	G	H	I	
24900/10/FF	M10X50	35	50	Ø 80	14	M10	25	85	108	10000
25000/10/FF	M10X75	35	75	Ø 80	14	M10	25	110	108	10000
25002/10/FF	M10X100	35	100	Ø 80	14	M10	25	135	108	10000
25004/10/FF	M10X125	35	125	Ø 80	14	M10	25	160	108	10000
24900/12/FF	M12X50	35	50	Ø 80	14	M12	25	85	108	10000
25000/12/FF	M12X75	35	75	Ø 80	14	M12	25	110	108	10000
25002/12/FF	M12X100	35	100	Ø 80	14	M12	25	135	108	10000
25004/12/FF	M12X125	35	125	Ø 80	14	M12	25	160	108	10000
25006/12/FF	M12X150	35	150	Ø 80	14	M12	25	185	108	10000
25000/FF	M14X75	35	75	Ø 80	14	M14	25	110	108	10000
25002/FF	M14X100	35	100	Ø 80	14	M14	25	135	108	10000
25004/FF	M14X125	35	125	Ø 80	14	M14	25	160	108	10000
25006/FF	M14X150	35	150	Ø 80	14	M14	25	185	108	10000
25008/FF	M14X175	35	175	Ø 80	14	M14	25	210	108	10000
25020/FF	M16X75	38	75	Ø 80	13*	M16	25	113	108	10000
25022/FF	M16X100	38	100	Ø 80	13*	M16	25	138	108	10000
25024/FF	M16X125	38	125	Ø 80	13*	M16	25	163	108	10000
25026/FF	M16X150	38	150	Ø 80	13*	M16	25	188	108	10000
25028/FF	M16X175	38	175	Ø 80	13*	M16	25	213	108	10000
25030/FF	M16x200	38	200	Ø 80	13*	M16	25	235	108	10000
25040/FF	M20X75	38	75	Ø 80	17*	M20	25	113	108	10000
25042/FF	M20X100	38	100	Ø 80	17*	M20	25	138	108	10000
25044/FF	M20X125	38	125	Ø 80	17*	M20	25	163	108	10000
25046/FF	M20X150	38	150	Ø 80	17*	M20	25	188	108	10000
25048/FF	M20X175	38	175	Ø 80	17*	M20	25	213	108	10000
25050/FF	M20X200	38	200	Ø 80	17*	M20	25	238	108	10000
25052/FF	M20X225	38	225	Ø 80	17*	M20	25	260	108	10000
25054/FF	M20x250	38	250	Ø 80	17*	M20	25	285	108	10000
25070/FF	M24X75	40	75	Ø 80	20*	M24	25	115	108	10000
25072/FF	M24X100	40	100	Ø 80	20*	M24	25	140	108	10000
25074/FF	M24X125	40	125	Ø 80	20*	M24	25	165	108	10000
** 25076/FF	M24X150	40	150	Ø 80	20*	M24	25	190	108	10000
** 25078/FF	M24X175	40	175	Ø 80	20*	M24	25	215	108	10000
** 25080/FF	M24X200	40	200	Ø 80	20*	M24	25	240	108	10000
** 25082/FF	M24X225	40	225	Ø 80	20*	M24	25	265	108	10000

* N°2 fresature
Two flat sides

** Disponibile con Filettatura a passo fine. Aggiungere "/P2" al codice
Available with Thin pitch thread. Please, add "/P2" to the code